

## Mounting of Surface Mount Components

### Introduction

Over the past few years, electronic products, and especially those which fall within the category of Consumer Electronics, have been significantly reduced in physical size and weight.

Products such as cellular telephones, lap-top computers, pagers, camcorders, etc., have been reduced by as much as 3/4 of their original introductory size and weight. The most significant contributing factor to this reduction has been the inclusion of fine pitch, Surface Mount (SM) components. The larger, thicker and heavier leaded Through-Hole (TH) packages consumed far too much power, too much space and contributed significantly to the total weight of the final product.

Product manufacturers were listening when the customer said "Make it smaller, lighter and less expensive".

A second phase to this continued reduction in package size and weight is currently being experienced. A new family of sub-miniature surface mounted packages known under the industry's generic name of Chip Scale Packages (CSP) have recently been introduced. CSP size components are currently the basis of a new series of consumer products. CSP components are currently being supplied in two (2) package configurations, both of which will be a maximum of 1.2 X of the die size. One incorporates planar or bumped pad interconnections on the peripheral of the package underside. The other package is in the form of a reduced scale ball grid array either in a partially or fully populated I/O condition.

The increasing availability of the CSP significantly impacts the ability of product designers to design hand-held products of a size and weight not previously possible. The new CSP allows a higher density of components to be placed into an increasingly smaller portion of an existing printed circuit board, or that the printed circuit board may be reduced with an accompanying reduction in product size, weight and cost. Chip Scale Packages incorporating high I/O dies, along with discrete passive components are currently used in the design of the palm-sized camcorders. As a residual benefit, with components in closer proximity the signal propagation time is reduced thus producing a series of faster circuits.

Accompanying the benefits of smaller size, reduced weight, higher density and increased performance, the individual Methods, Technologies and Techniques used to assemble printed circuit board assemblies have been impacted.

### Component Size Comparison

Molded Dip, SOIC, CSP - 24 Pin

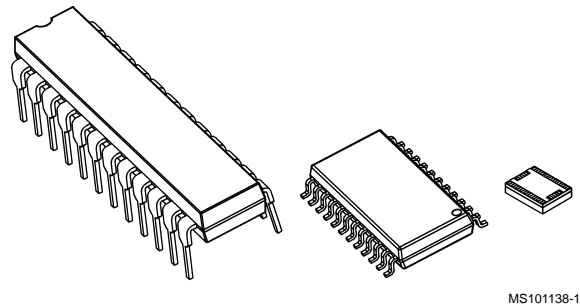

MS101138-1

Molded Dip, SOIC, micro-SMD - 8 Pin

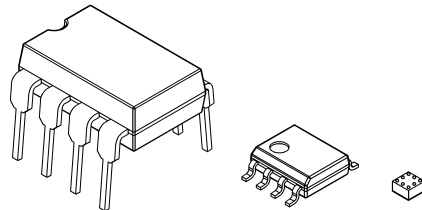

MS101138-2

The Surface Mount (SM) package was developed to provide the customer with increased component density and performance over the larger Dual-Inline-Package (DIP). The SM package also provides the same DIP high reliability.

The Chip Scale Package (CSP) was developed to provide the customer with an additional increase in component performance and density over the SM package. The CSP also provides the same high reliability as the DIP and SM package.

TSSOP & CSP - 24 pin

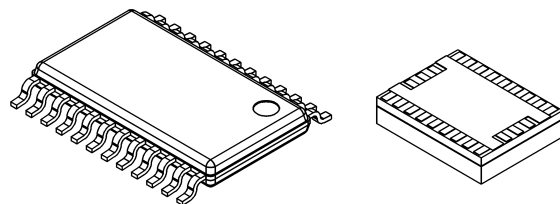

MS101138-3

CSP and SM packages at National were internally qualified for production under the condition that they be of comparable reliability performance to a standard dual in line package under all accelerated environmental tests.

## Accelerated Bias Moisture Test DIP, SO's, & CSP

Figure 1 is a summary of accelerated environmental bias moisture test performance on 15V CMOS and 30V BIPO-LAR product assembled in SM and DIP (control) packages.

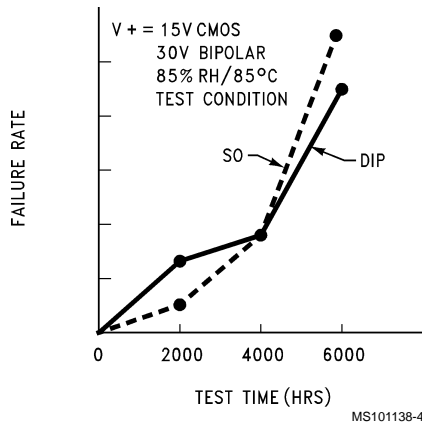

## PCB Assembly Flows

### Through-Hole (TH) Technology

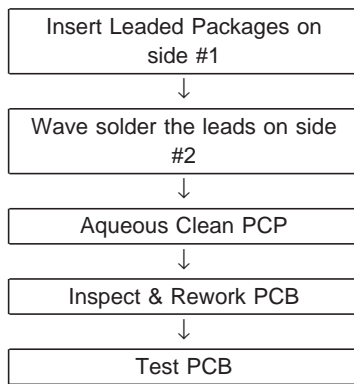

### Mixed Technologies - TH Side 1 & Passive SM Side 2

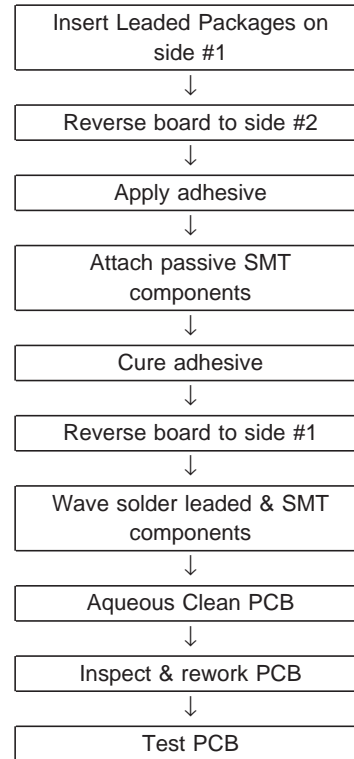

### Thermal Stress - Side 2 Surface Mount

During the wave solder operation, the side 1 TH components are subjected to significantly less thermal stress than the side 2 bottom side SM mounted components. Only the TH leads come in contact with the molten solder, compared to the entire SM package being immersed in molten solder.

Figure 2 illustrates a comparison of package temperature versus wave soldering dwell time for TH components mounted on side 1, with SM packages mounted on side 2.

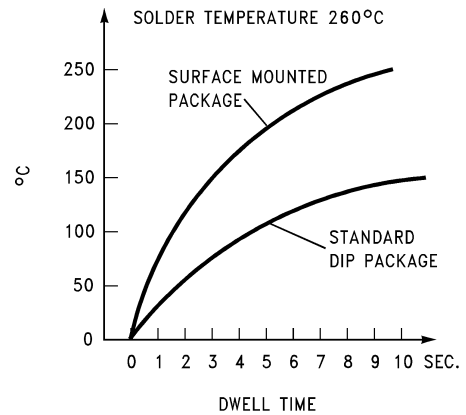

Under ideal conditions, the rate of thermal expansion of package lead frame and plastic encapsulant would be the same. When both materials expand at the same rate during thermal excursions, bonds between metal and plastic maintain a mechanical integrity. Because it is difficult and costly to tailor an epoxy encapsulant material to meet the Coefficient of Thermal Expansion (CTE) of the metal lead frame, a mis-

## PCB Assembly Flows (Continued)

match at some point in the thermal excursion will occur, possibly producing an opening by which contaminants may enter.

Normally, thermal expansion rates for epoxy encapsulant and metal lead frame materials are linear and remain fairly close at temperatures approaching 160 Deg C displayed in Figure 3. At lower temperatures the difference in expansion rate of the two materials is not great enough to cause interface separation.

However, when the package reaches the glass-transition temperature (Tg) of epoxy (typically 160 - 165 Deg C), the thermal expansion rate of the encapsulant increases sharply, and the material undergoes a transition into a plastic state. The epoxy begins to expand at a rate three times or more greater than the metal lead frame, causing a separation at the interface.

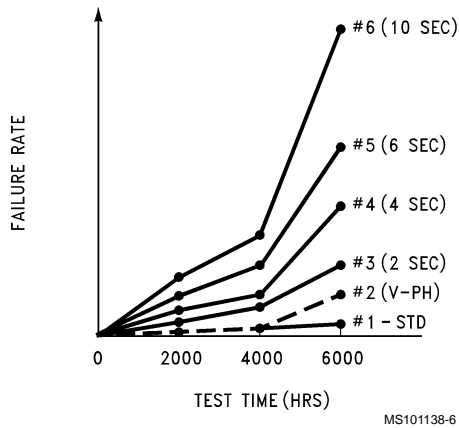

FIGURE 3. Immersion in 360°C Solder

## Mixed Technologies - TH & SM Side 1 & SM on Side 2

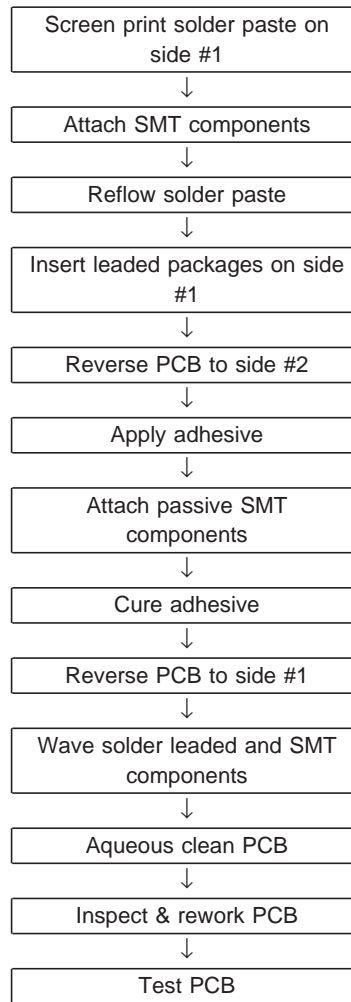
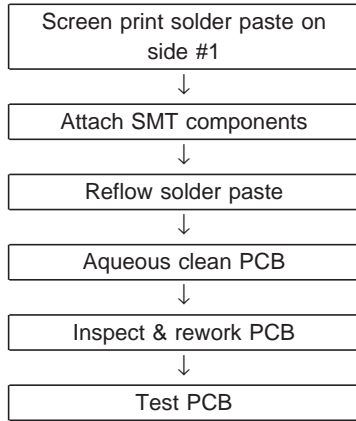

TABLE 1. Surface mount packages recommended for Wave Solder Immersion.

Package Type	Lead Count							
	3	4	5	6	8	14	16	20
SC-70			X					
SOT-23	X		X	X				
SOT-223		X	X					
SOIC - NARROW					X	X	X	
SOIC - WIDE						X	X	X

- Please verify through device specific application notes.
- All other packages and lead types are not recommended.

**Surface Mount Technology - Single Sided PCB**



**Surface Mount Technologies - Double Sided PCB**

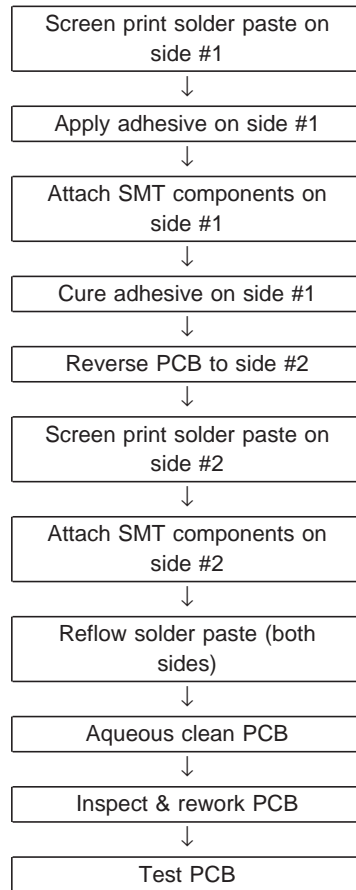

**Changing Assembly Techniques & Technologies**

**Combined Wave Solder and Solder Reflow**

More mature products incorporating printed circuit boards designed with Through-Hole (TH) semiconductors in a Dual-In-Line (DIP) package and with TH axial leaded components, require bottom side board wave soldering for component to pad interconnection.

Specified packages (see *Table 1*) may be mounted on the underside (side 2) of the board using this same solder attachment technique. This assembly technique allows better utilization of the PCB underside, thus freeing up top side real estate for high lead count active components.

Securement of the bottom side (side 2) SM components is achieved through the use of a cured adhesive applied prior to the wave soldering application. Component Engineers responsible for components selected for bottom side SM mounted components had to take into consideration that these components were subjected to the same time and temperature wave soldering profile experienced by only the leads of leaded TH components and selected these SM components accordingly.

**Fine Pitch SM Solder Reflow Side 1 and Side 2**

Fine pitch SM components are routinely mounted both on side 1 and side 2 with no use of adhesive. The one exception to this rule is when the component possesses a larger body mass in relation to the strength of the total volume of solder paste incorporated in the component interconnection.

**Purpose of Solder Paste**

Solder paste provides both the metals and the cleaning agent used to produce the pad interconnection of package lead to printed circuit board pad.

The purpose of the fluxing system within the paste is to provide clean, positive wettable surfaces to which the metal solder bonds, thus allowing the electrical interconnection to be produced. The fluxing system operates as the cleaning agent required to remove potential oxides from both the package lead/pad and the board pad. The fluxing system also provides protection of the newly cleaned metal surfaces from re-oxidation during the soldering operation while the lead and pad is at their highest temperature.

**Types Of Solder Paste Fluxes**

The fluxing system is composed of a flux and binder system used in solder paste, and is generally divided into the categories of Rosin-based, Water Soluble and No-Clean.

- Rosin-based fluxes are designated
  - R Rosin, non-activated
  - RMA Rosin, mildly activated
  - RA Rosin, fully activated
- Water Soluble fluxes are designated
  - WS Water-soluble
- No-Clean fluxes are designated
  - NC No-Cleaning required

### Comparison of Particle Size / Shape of Various Solder Pastes

200 x Alpha (62/36/2)

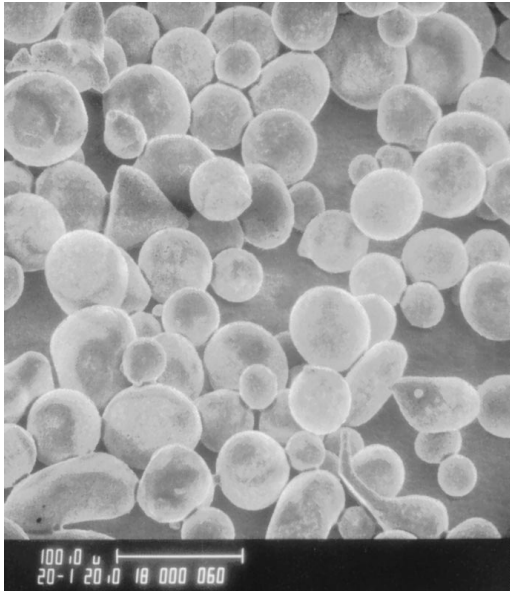

MS101138-7

200 x Kester (63/37)

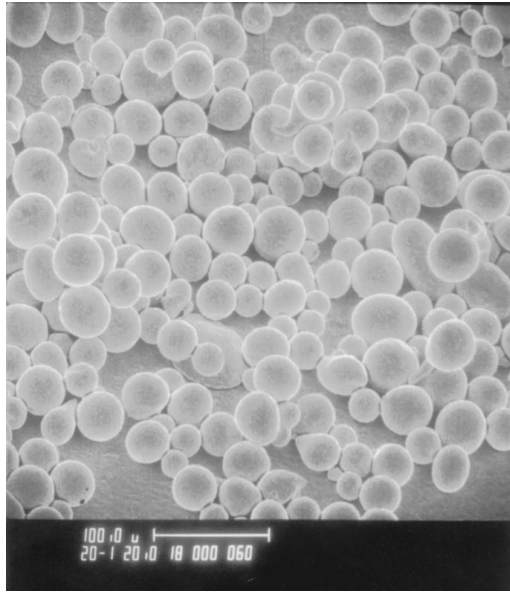

MS101138-8

Solder Paste Screened on Pads

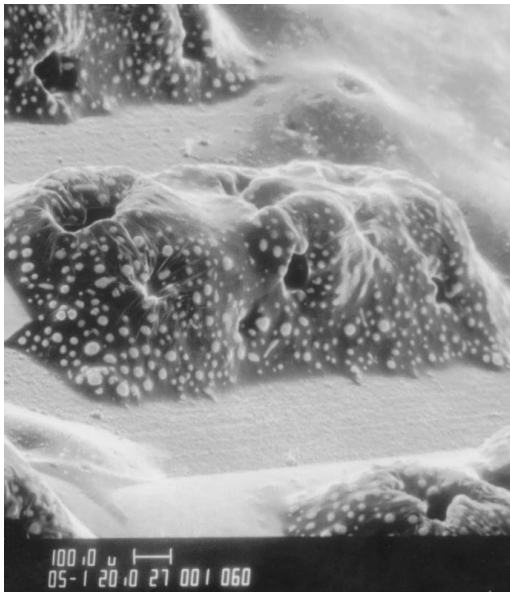

MS101138-9

200 x ESL (63/37)

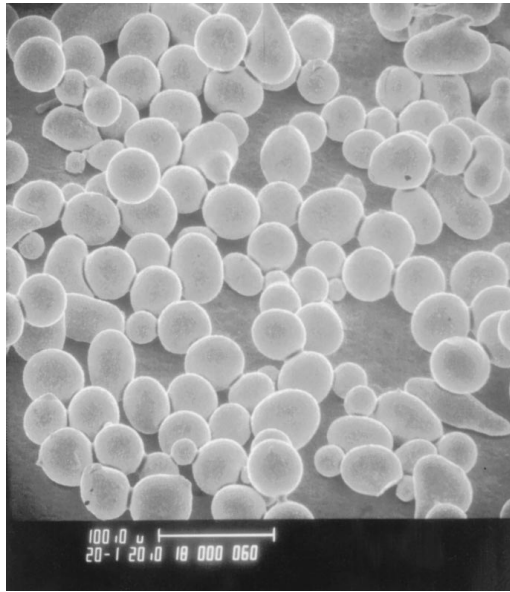

MS101138-10

## Solder Paste For Standard SM Packages

Consistency and uniformity is the key for any successful solder paste material. The basic requirement is a stable and homogeneous blend of atomized metal alloy combined with a flux, binder, and solvent system which eliminates the possibility of later separation of the respective materials. These qualities are required to ensure a predictable screening and stenciling printing operation producing the required pattern definition.

The selected solder paste should be formulated so as to eliminate potential breakdown of the metal, flux, binder, and solvents combination, or the premature drying of the solder paste on the printer. Both of the previously cited qualities should be in addition to providing a minimum of 48 hours tack time. The selected solder paste should be formulated so as to prevent slump and provide over 8 hours of screen working life, with no presence of skipping, scooping and clumping during printing.

For screen printing of standard pitch SM packages, the metal alloy powders should be spherical in shape with a minimal oxide content and screened to 45-75 micron particle size. The paste should contain a minimum of 88% to 90% metal content, and have a viscosity of 500,000 to 600,000 centipoise.

For stencil printing of standard pitch SM packages, the metal alloy powders shape, size and content should remain the same but the viscosity should be increased to 700,000 or 800,000 centipoise.

In most cases, R, RMA and RA rosin-based fluxes will normally be removed using an aqueous de-ionized heated water cleaning system, augmented with a saponifier or another surfactant additive. The resultant cleaning water should produce biodegradable saponified products.

### Solder Paste For Fine Pitch SM Packages

Those solder pastes specifically designed for high lead count, fine pitch packages with lead spacing of 0.015" require a unique formulation for stenciling, screening and automatic point to point dispensing.

Solder pastes specifically formulated for fine pitch SM components should incorporate all of the previously cited qualities, plus a flux system developed specifically to ensure that no slumping while still in the wet stage. Fine pitch solder paste should not produce bridging, shorting or solder balling when the paste experiences the reflow.

As is in the case of Standard Pitch SM components, R, RMA and RA rosin-based fluxes will normally be removed using hot de-ionized water, augmented with a surfactant or other additive.

### Water Soluble Solder Paste For Fine Pitch Surface Mount Packages

Water soluble solder pastes should display all of the stencil or screen printing qualities displayed by conventional rosin-based pastes, but should also eliminate the need for chlorofluorocarbons, chlorocarbons or other solvent blends sometimes used for rosin-based flux residue removal.

Although they are soluble in water, water soluble pastes should not be hygroscopic and should be formulated to provide up to 8 hours of screen working life and 48 hours of tack time similar to rosin-based pastes.

Water soluble, fine solder pastes should be halogen-free. The water-soluble residues should be capable of being

cleaned to the extent that they are equivalent in performance, water extract resistivity and SIR values to standard RMA fluxes. Flux residues should be able to be removed with a cool presoak followed by a 140 Deg. F spray.

### Stencil Thickness

SM Lead Pitch	
inch	mm
0.050	1.27
0.025	0.63
0.015 to 0.020	0.4 to 0.5

Recommended Stencil Thickness	
inch	mm
0.008 to 0.010	0.20 to 0.25
0.006 to 0.008	0.15 to 0.20
0.004 to 0.006	0.10 to 0.15

### Stencil Materials

Stainless Steel is the most prevalent material used to produce stencils, but brass, Alloy 42, molybdenum and nickel plated brass are also used.

### Squeegee

Metal is the most common material used to produce squeegees. The justification for the use of metal is that it produces a uniform surface across the top surface of the stencil without scooping down into the just deposited solder paste.

Rubber of an 80 to 90 Durometer reading is also used.

### Print Speed

Printing speeds of 0.5 to 2.5 inches (15 to 65 mm) per second are normally used, depending on type and capabilities of the solder printing machine.

### Print Pressure

During the solder paste printing operation, sufficient downward pressure should be exerted by the squeegee against the stencil surface to wipe the stencil clean. Although the printing pressure will vary with the type of printer, typically a pressure of 1.25 to 2.5 lbs per inch of squeegee length is acceptable.

### Off And On Contact

Both contact and non-contact techniques are used successfully. If non-contact is used, a snap-off of up to 0.005 is recommended.

### Temperature And Humidity

The screen printing of solder paste should be performed between a temperature of 68° to 78° F (20° to 26° C). The relative humidity of the application area should be kept between 35% to 65%. Solder paste not applied to printed circuit boards should not be returned to the container from which it was taken.

### Stencil And Screen Cleaning

Stencils and screens should be cleaned of unused solder paste using water heated to a minimum of 140 Deg F in conjunction with a pressure spray. Although the initial water need not be deionized, it is recommended that a final rinse be performed using deionized water, followed by an isopro-

## Solder Paste For Standard SM Packages (Continued)

panol rinse. This same procedure should also be followed for any hand tools and the squeegee used to apply the solder paste.

At no time should the stencil, screen or tools which have come in contact with unreflowed solder paste be cleaned in equipment used to clean printed circuit boards of reflowed solder paste residues.

## Component Placement System

### System Configuration and Specifications

Product designs continue to demand continued down-sizing of the component package, accompanied by higher board densities. The component placement system must accommodate these trends by employing a highly accurate, computer controlled, camera directed placement nozzle that is responsible for constraining the component during pick-up through push-off after placement.

Following are some of the more significant elements devised by the system vendors there by enabling the placement system to produce high speed, high density accurate component placements:

- Computer controller
- Windows or vendor software
- Vision correction system
- Component body height adjustment
- Z-Axis placement programmability
- Single Head - Multiple programmable nozzles
- Dual Head - Multiple programmable nozzles
- Dual Head - 6 nozzles per head
- Dual Work Table - 12 heads with 3 nozzles per head

### Placement System

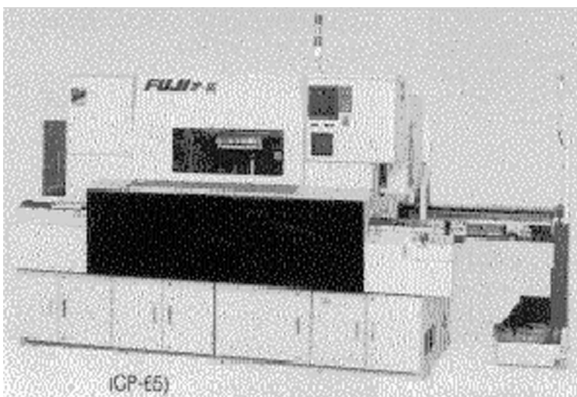

MS101138-11

### Placing Heads

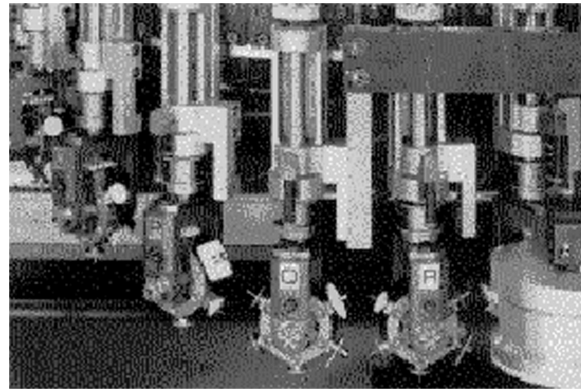

MS101138-12

### Component Types

The types of components which may be placed are generally only restricted by the types of feeders that may be interfaced to the placement system. Following are some representative component types which are being automatically picked and placed by placement systems of the latest design:

1. Chips
2. CSP
3. QFP
4. TAB
5. BGA
6. MELF
7. SOIC
8. PLCC
9. TSOP
10. TSSOP
11. Flip Chip

### Component In-Feeding Systems

With the introduction of the embossed (pocketed) tape, more package types are being supplied in this format due to increased end-user demand. The embossed tape provides the end-user the ability to maintain an improved quantity and quality control through the use of the see-through tape and the rigid cardboard sidewalls of the shipping reel. Paper tape is normally only used to provide the smallest types and values of discrete, passive components.

- 8 mm paper tape
- 8 mm embossed tape
- 12 mm embossed tape
- 16 mm embossed tape
- 24 mm embossed tape
- 32 mm embossed tape
- 48 mm embossed tape
- Stick in-feeding
- Tray in-feeding
- Ultra-small chips up to 4.5 mm
- Medium-sized odd form components up to 28.0 mm
- Large odd form components up to 38.0 mm

## Component Placement System

(Continued)

- Extremely large odd form components up to 74.0 mm

### Printed Circuit Board Dimensions

Current placement systems are designed to provide the end user with the maximum printed circuit board size in both the X and Y axis. Most of the current designs will allow a change in the conveyor rail width to be automatically executed by servo motors by program commands conveyed through the computer controller.

- Min. 80 x 50 mm (3 x 2")
- Max. 508 x 457 mm (20 x 18")

### Vision Assisted Component Placement

The vision system should include as a basis element of the design, an ability to process (establish X/Y/Theta) the component location on the pick-up head and match the component to the respective component pads. To achieve the required placement accuracy, the following is necessary:

- Gray scale vision processing.
- Component placement algorithms.
- Fiducial (local and global) camera.
- Component pad/lead recognition camera.

### Placement Speed

Although placement speed is typically quoted at approximately 0.1 second per placement, Flip Chip components can take as long as 3.5 to 5.0 seconds per shot (placement). Component placement speed is dependent upon such factors as distance which the placement head must travel between component pick-up and placement location, and the requirement to view the component leads/pads for component-to-pad alignment prior to placement

- Min. 0.09 sec. per component
- Max. 0.12 sec. Per component

### Placement Accuracy

The accuracy to which the component is aligned and placed on the solder pads is contingent upon several factors, such as use of local fiducial marks; datum point location; size of printed circuit board; flatness of printed circuit board; etc.

- Min.  $\pm 0.025$  mm (using local fiducial marks)
- Max.  $\pm 0.1$  mm

### Component Pick-Up Head Types

The most favored technique of component pick-up is via the vacuum nozzle due to the system's ability to create a negative pressure instantly upon making contact with the top surface of the component with the soft rubber nozzle contact, and then reverse the process by producing a positive pressure to "blow" the component off the nozzle upon placement. Mechanical chucks, although favored for some time, are expensive to maintain and do present some mechanical difficulties in their operation.

- Vacuums Nozzles
- Mechanical Chucks

### Component Placement Pressure

Programmable placement pressure can be specified for each component, enabling placement of very delicate parts.

## Convection Reflow Furnace

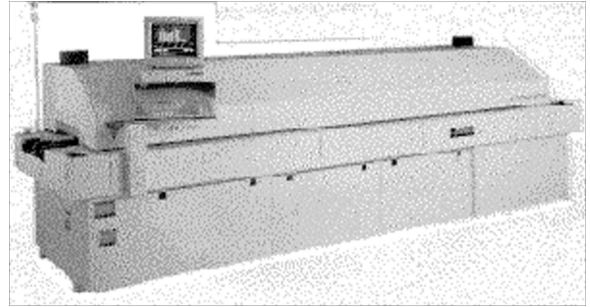

MS101138-13

## Techniques of Solder Interconnection

Solder interconnection of Through-Hole and Surface Mount components to printed circuit boards may be classified as using the following two (2) categories:

### Local Component Heating

Local heating can be divided into the following methods:

- Hot plates with solder paste or flux.
- Hand solder iron with solder and flux.
- Hot bar (pulsed heater) using solder paste or flux.
- Hot air gun using solder paste or flux.
- Directed laser energy using solder paste or flux.

### Global Board Heating

Global heating is divided into the following methods:

- Solder submersion.
- Directed IR reflow using solder paste.
- Hot air furnace reflow using solder paste.
- Vapor phase reflow using solder paste.
- Convection furnace reflow using solder paste.

As is displayed by the various soldering techniques above, solder paste is the dominant method of attaching electrical components to printed circuit boards.

### Thermal Processing (Reflow) System

In a similar fashion as in the case of the component placement system, the specifications for thermal processing system will be developed based upon the anticipated reflow soldering requirements throughout the life of the oven. This statement is true for not only the type and configuration of the components currently being soldered, but also any adhesive which would require curing.

Taken into consideration will be whether the components of a surface mount design are leaded or leadless the physical size and robustness of the component to withstand reflow temperatures. Because most components being designed into today's products are of a reduced mechanical configuration and located in close proximity to each other on smaller printed boards, the selection of the technology used within the reflow system becomes even more critical.

Following are only some of the more critical decisions which will be made concerning the more pertinent parameters of the thermal processing system selection:



## Techniques of Solder Interconnection (Continued)

### Product Throughput

Is the reflow oven "sized" for the current and anticipated production requirements. This will require not only a determination as to the number of boards the oven will process, but also how the boards will be conveyed through the oven.

### Thermal Uniformity and Accuracy

The reflow system should provide a uniform heat transfer from the heating source, distributing it evenly over the product surfaces under process in an accurate manner so that all of the board surfaces receives an equal temperature rise. The same criteria is required for cooling.

### Nitrogen Consumption

The infusion of nitrogen immediately prior to and during the solder paste reflow operation is mandated by the process and materials being assembled. Specifically, bare-copper circuit boards, and no-clean solder pastes benefit from the inclusion of the nitrogen atmosphere.

Certain No-Clean solder paste with a metal alloy content of greater than 98% will often require the use of Nitrogen because the remaining 2% (by weight) or less will contain an insufficient amount of flux material available to prevent oxidation of the soldered elements if reflowed in an air environment.

Should the process and materials being assembled require nitrogen, features within the oven design should be present which minimizes nitrogen consumption during preheat, soak, reflow, and cool.

### Infrared Radiation (I.R) Reflow Soldering

Radiant I.R. is a direct, focused heat source and was the initial heating technique used by the electronics industry to reflow solder paste. This technique, when not properly adjusted in relation to the board distance, could allow excessive amounts of directly focused heat to be delivered to the surface of the board producing a scorching effect to the board and the components under reflow.

This technique is no longer commercially viable.

### Natural Convection Reflow Soldering

Natural convection of the heat required to reflow the solder is normally obtained through the use of a non-focused I.R. source, without the benefit of a forced air circulation. This design is often referred to as "non-focused", with the efficiency capability rated lower than the forced convection design due to the ability of larger components to shield smaller components from the available heat source.

### Forced Convection Reflow Soldering

Heat require to reflow the solder paste is achieved by directing I.R. energy towards a metal or ceramic surface and utilizing the convected (radiated) energy from the opposite surface to produce the reflow.

The heat is circulated within the reflow zones by strategically located fans. By use of a non-directed, convected heat circulated via strategically located fans, hot spots on the boards can potentially be eliminated.

### Fixed Convection Reflow Soldering

Fixed Convection reflow soldering utilizes much of the same technology as Forced Convection with the exception of the use of strategically located fans.

### Heating Zones

The number of heating zones required will be determined by current and anticipated product throughput requirements, product size and physical mass, product orientation within the oven while on the conveyor, and requirements dictated by the particular solder paste reflow profile. Reflow ovens are typically offered in ranges from four to 12 heating zones.

### Active Cooling Zones

Active cooling zones should be positioned immediately adjacent to the heating zones and should be ideally provided to meet the reflow requirements specified by the solder paste manufacturer.

The amount of cooling required may also be dictated by product handling or subsequent assembly operations following reflow.

Depending on the system requirements and vendor capability, the number of cooling zones which may be incorporated into the system may range from one to 12.

## Pcb Assembly Cleaning

If the printed circuit boards were assembled using a rosin based or other flux system which requires removal from the board surface after reflow, the subsequent cleaning operation should be performed as shortly after reflow as possible.

The timely initiation of the cleaning operation is dictated by the ability of the flux to collect and harden with additional residues under and around traces and the bodies of components. The lack of attention to the timely removal of this residue present additional and unneeded removal difficulties, with the possibility that some contaminates may be trapped in flux and remain on the surface of the board to potentially compromise qualities for the finished product.

## Pcb Cleaning Test

Upon completion of the solder reflow operation the surface mount assembly should be tested for ionic and other contaminates using recognized specification, such as IPC-6012.

If the printed circuit board is to have a permanent solder mask coating applied, the bare uncoated board should be also tested for ionic and other contaminates prior to permanent coating.

## SM Reflow Soldering Reliability

More recently designed products utilizing the low profile, high lead count, fine pitch SM components, when combined with Chip Scale Packages present additional challenges to the techniques and technologies of high reliability component interconnection.

The potential obstacles of high reliability fine pitch SM and reduced size CSP component interconnections are contingent upon a number of parameters, with the most prevalent being:

- Technology and package construction.
- Quality and repeatability of the reflow process.
- Metallurgy and uniformity of both the solder paste and interconnection pad plating.
- Individual board design, both internally and externally.

## SM Reflow Soldering Reliability

(Continued)

- Conditions in which the product will be used.
- What is the intended product life.

Reliability level demands are higher for products using the new low profile, fine-pitch, high lead count miniature IC packages, such as CSP and reduced size BGA over assemblies built around older, more conventional packages with their longer and more compliant leads.

## Thermal Characteristics of SM Components

Both Chip Scale Packages and SM components are typically fabricated using a combination of either a metal lead frame;

laminated substrate; ceramic substrate, or flexible film substrate as a base on which a die is adhesively attached. Gold wires are bonded from die to lead frame/substrate, and the unit is encapsulated, with a thermoset epoxy.

Because each material has different rate of thermal expansion, the thermal characteristics of the materials generally correspond to a Thermal Mechanical Analysis (TMA) graph.

### LIFE SUPPORT POLICY

NATIONAL'S PRODUCTS ARE NOT AUTHORIZED FOR USE AS CRITICAL COMPONENTS IN LIFE SUPPORT DEVICES OR SYSTEMS WITHOUT THE EXPRESS WRITTEN APPROVAL OF THE PRESIDENT AND GENERAL COUNSEL OF NATIONAL SEMICONDUCTOR CORPORATION. As used herein:

1. Life support devices or systems are devices or systems which, (a) are intended for surgical implant into the body, or (b) support or sustain life, and whose failure to perform when properly used in accordance with instructions for use provided in the labeling, can be reasonably expected to result in a significant injury to the user.
2. A critical component is any component of a life support device or system whose failure to perform can be reasonably expected to cause the failure of the life support device or system, or to affect its safety or effectiveness.



**National Semiconductor Corporation**  
Americas  
Tel: 1-800-272-9959  
Fax: 1-800-737-7018  
Email: support@nsc.com  
www.national.com

**National Semiconductor Europe**  
Fax: +49 (0) 180-530 85 86  
Email: europe.support@nsc.com  
Deutsch Tel: +49 (0) 69 9508 6208  
English Tel: +44 (0) 870 24 0 2171  
Français Tel: +33 (0) 1 41 91 87 90

**National Semiconductor Asia Pacific Customer Response Group**  
Tel: 65-2544466  
Fax: 65-2504466  
Email: ap.support@nsc.com

**National Semiconductor Japan Ltd.**  
Tel: 81-3-5639-7560  
Email: nsj.crc@jksmtp.nsc.com  
Fax: 81-3-5639-7507