

# Altium Designer – Simulation Tutorial

Last updated: 8/4/16, John Miller, Altium Designer 14.3

**IMPORTANT!** See the *Altium - Getting Started* tutorial before reading this one.

The following two sections will use the same circuit (below) with different sources.

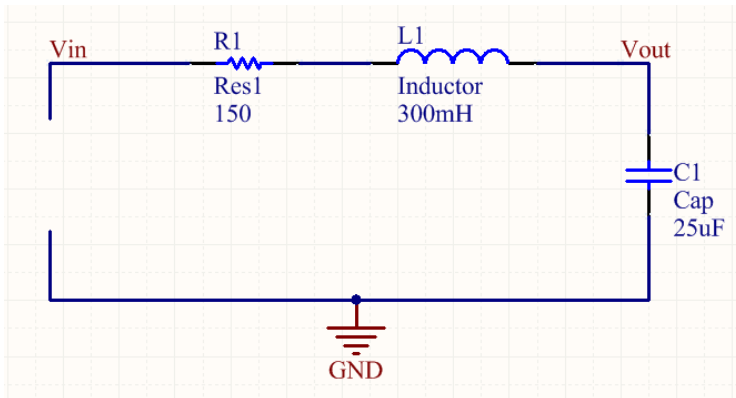

## Transient Simulation

1. The first step is to select and configure the input source. For transient analysis, we can use any of the simulation sources, but we are often interested in a step response. The easiest way to get a step input is to use a piece-wise linear source or **VPWL**. This means we will define the voltage at a series of points in time. The source will produce an output that changes linearly between each of these defined points. The following waveform would be produced by the sequence shown in the table.

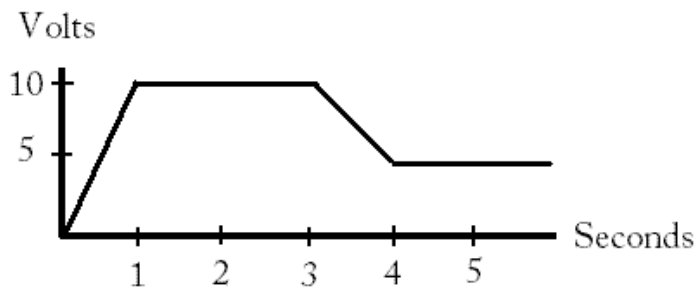

Time	Voltage
0 s	0 V
1 s	10 V
3 s	10 V
4 s	5 V

2. To do this in Altium, first place the VPWL source. Then double-click to open the Properties dialog. Click the **Edit** button in the Models section (lower right).

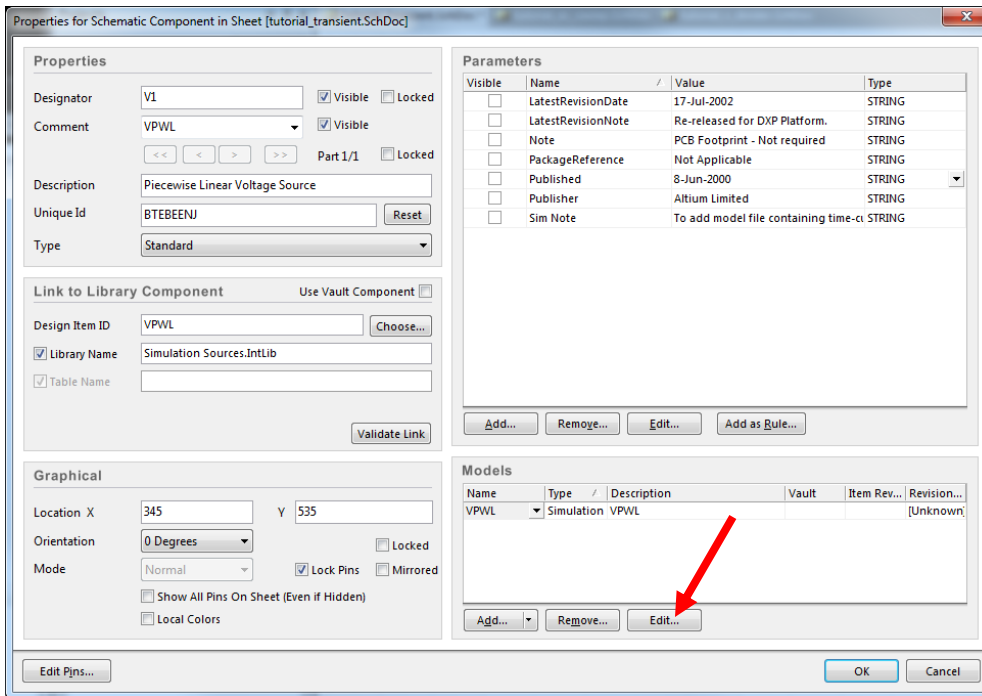

- This brings up a second dialog. Click the **Parameters** tab (red arrow). You should have the dialog below. You can edit the table here or...

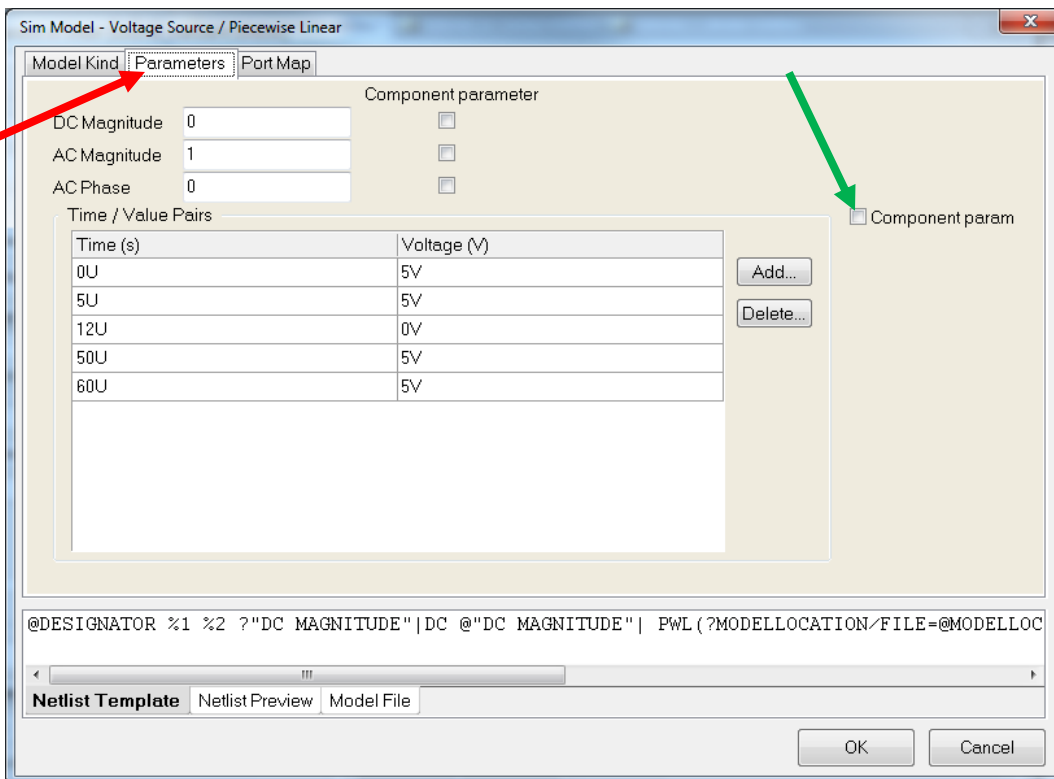

4. Checking the “Component param” box (green arrow above), and clicking OK twice, will display the sequence on your schematic, which you can edit directly.

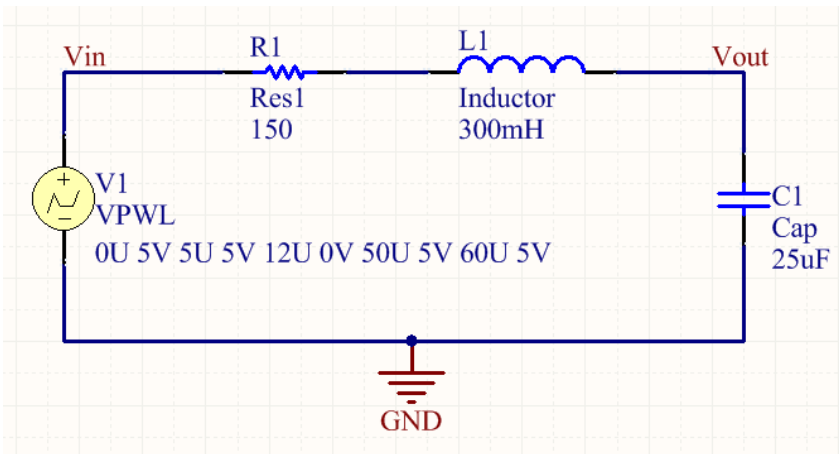

5. For our simulation, we want to do a simple step function, meaning it transitions from 0 to 1 in an infinitesimal amount of time. Some programs require you to have a non-zero amount of time for the transition, but Altium will actually let you specify a 0 second time step, such as:  
0u 0V 0u 1V  
This means “at 0 microseconds output 0 V, then at 0 microseconds output 1 V.” Double-click the text string and enter that sequence. (It’s not case sensitive.)
6. Click the **Setup Mixed-Signal Simulation** icon (red arrow) on the simulation toolbar (or go to Design → Simulate → Mixed Sim). You can make the toolbar appear by going to View → Toolbars → Mixed Sim.

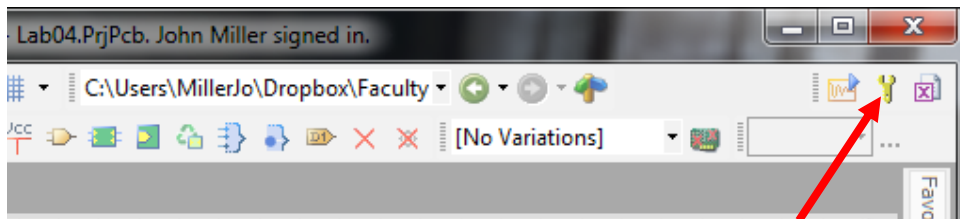

7. The following dialog appears. Your values for the fields *Collect Data for* and *Sheets to Netlist* should be the same as below by default. Also leave the *SimView Setup* option as **Keep last setup** (red arrow). This will maintain any modifications we make to the display of the waveforms. Under *Available Signals*, select **IN**, **OUT**, and **C1[i]** and click the arrow (green arrow) to move them to the *Active Signals* list. Click OK.

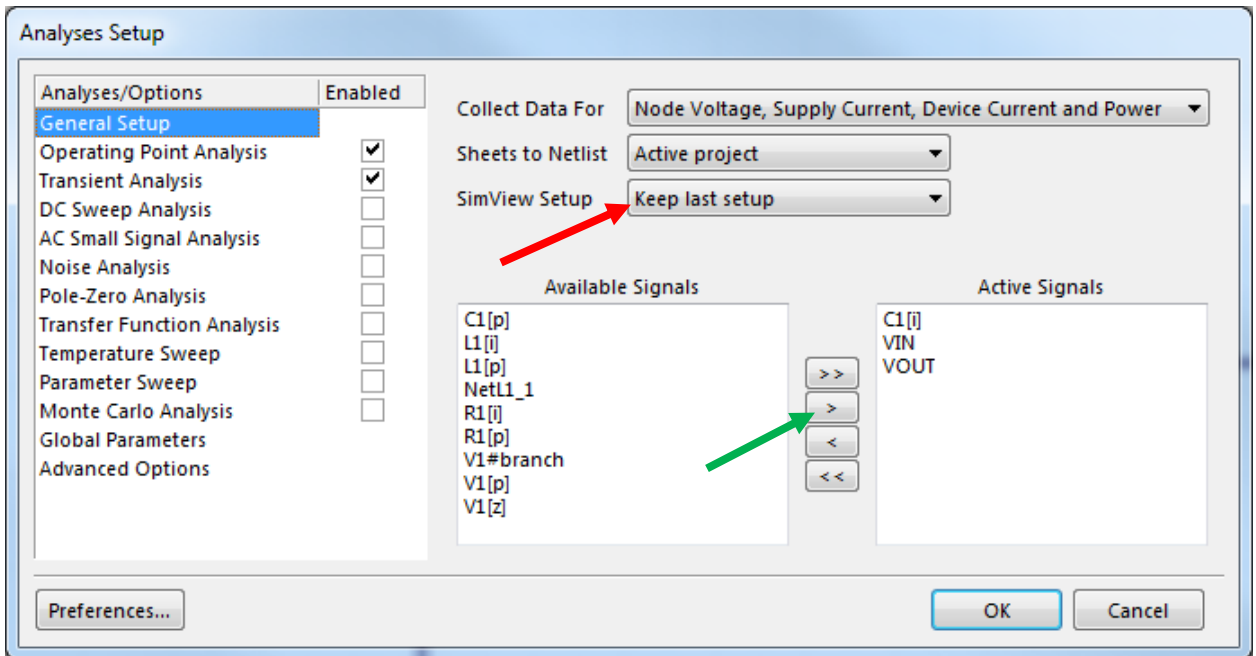

- Click on **Transient Analysis** to bring up the transient analysis options. Uncheck the “Use Transient Defaults” box (red arrow). Set the Stop Time to be 50 ms and the Step Time to be 50 us. (Note: one order of magnitude smaller than the length of the simulation is usually a good setting for step time. This will give you 1000 points in the simulation.). Be sure the Transient Analysis box is checked (on the left).

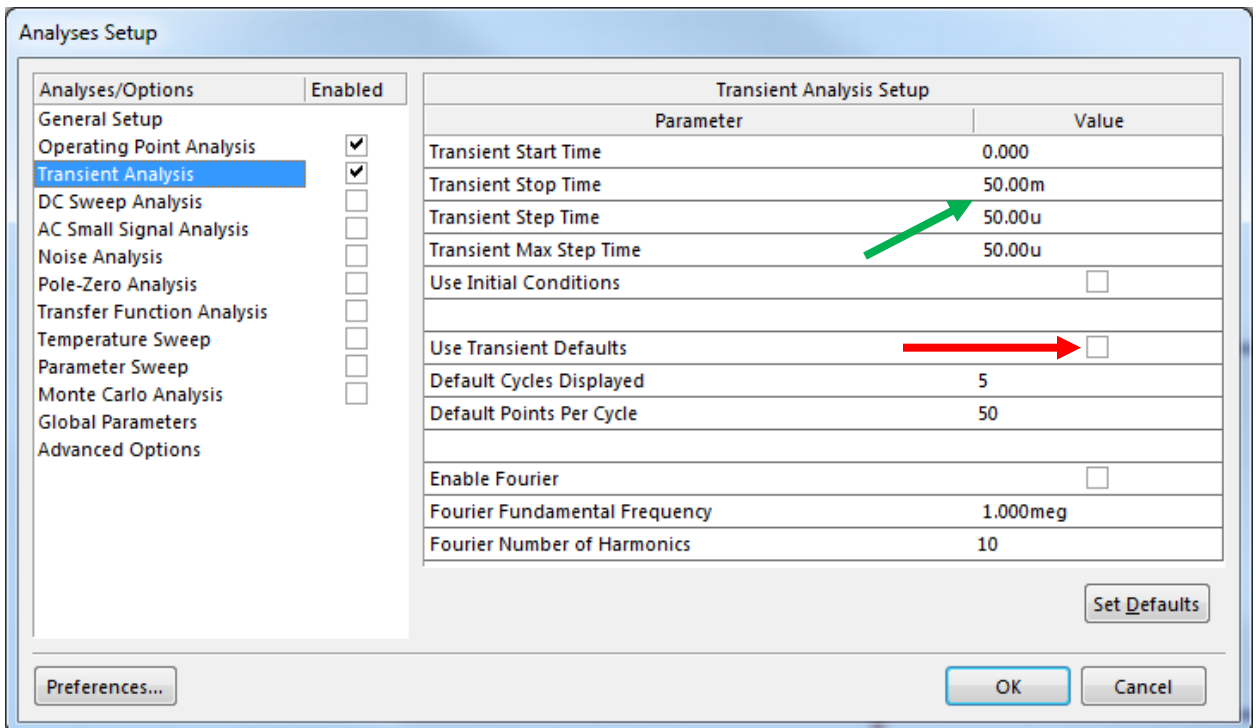

9. Click the **Run Mixed Signal Simulation** icon on the toolbar or press F9 (shortcut).

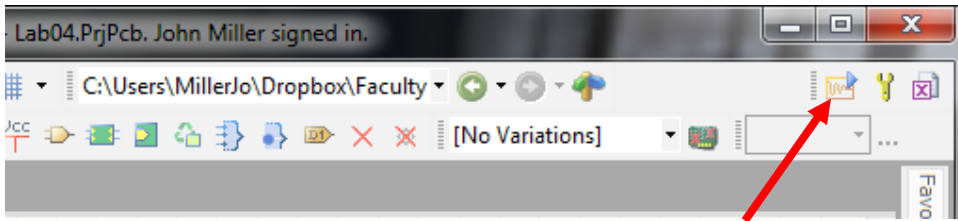

10. You should get the following results, showing the transient response for the three different signals we chose. We can now do lots of things with this.

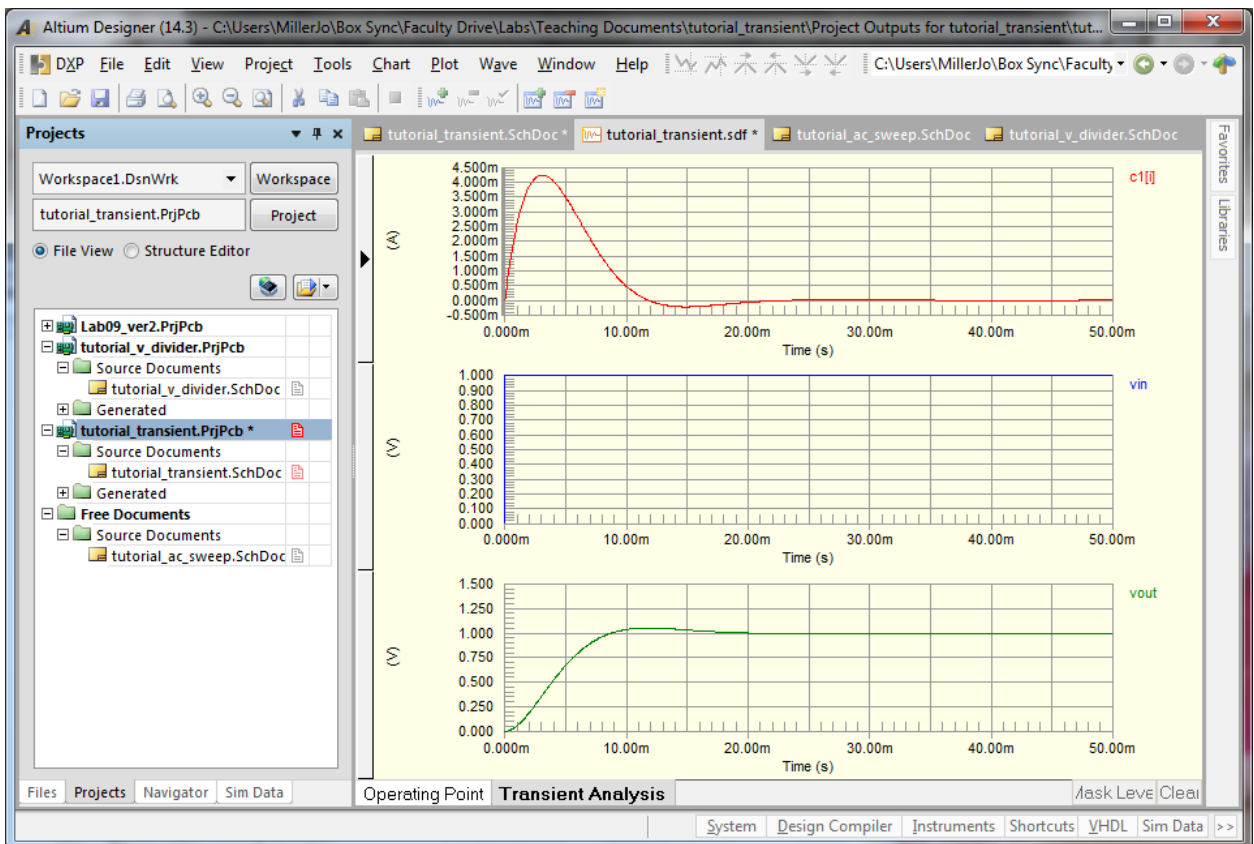

11. Let's start by improving the formatting. Right-click anywhere on the chart and choose **Document Options** to get the following dialog. Check the "Bold Waveforms" box. This makes the waveform lines thicker and easier to see.

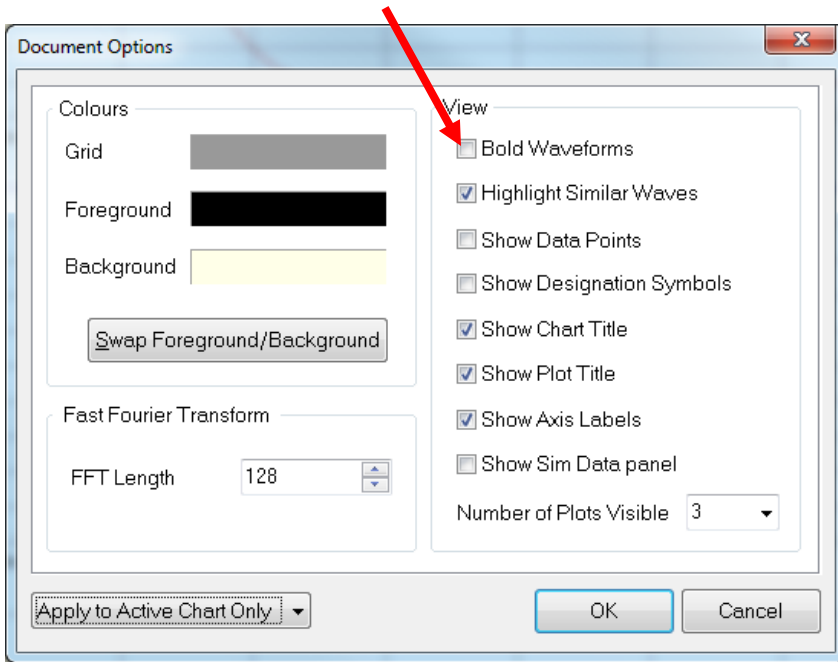

- Next, let's combine the  $V_{in}$  and  $V_{out}$  waveforms on the same plot (since they are both voltages and we are interested in the relationship between them). Right-click on the  $V_{out}$  plot (bottom) and click Delete. Click the **Sim Data** button (red arrow) or tab (green arrow) to bring up the Sim Data panel.

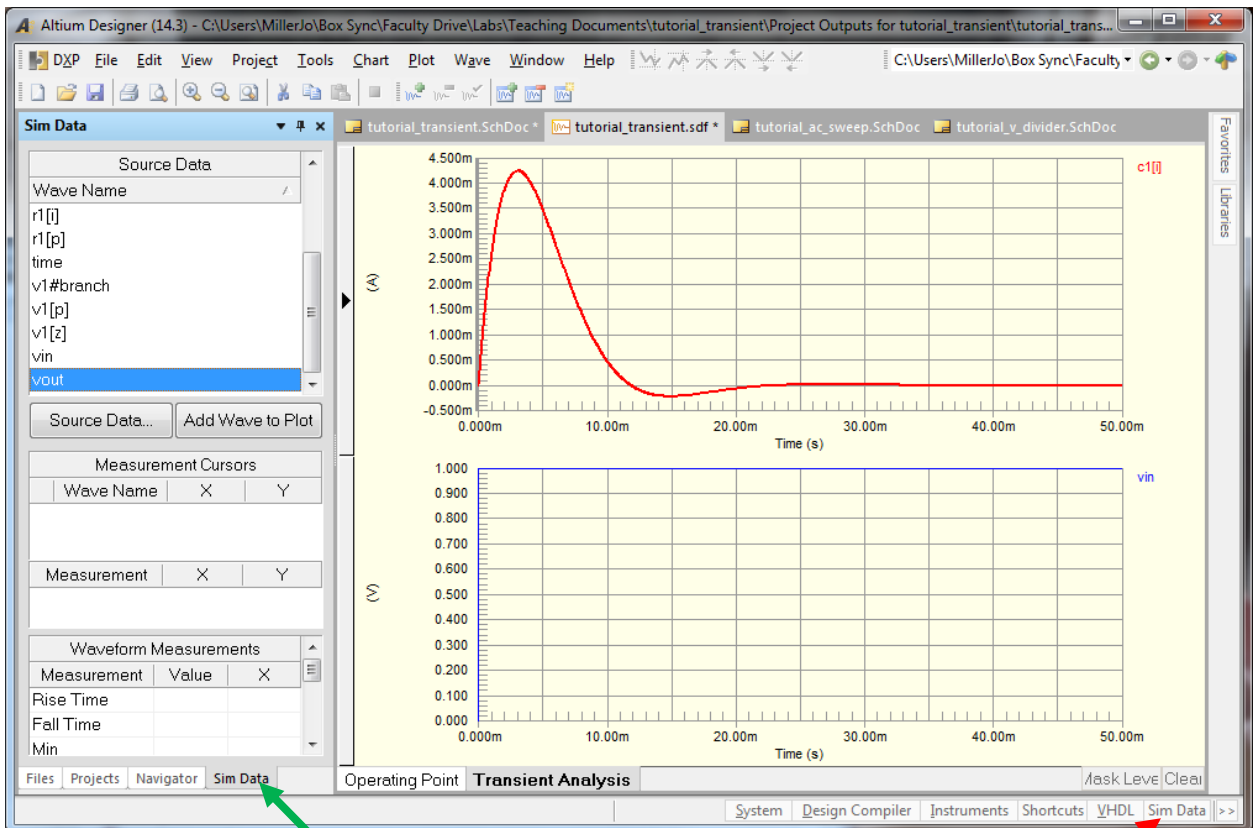

Click the lower plot to “select” it (or make it “active”), as indicated by the small black arrow (being highlighted by the red arrow). Select Vout in the Source Data list and click Add Wave to Plot.

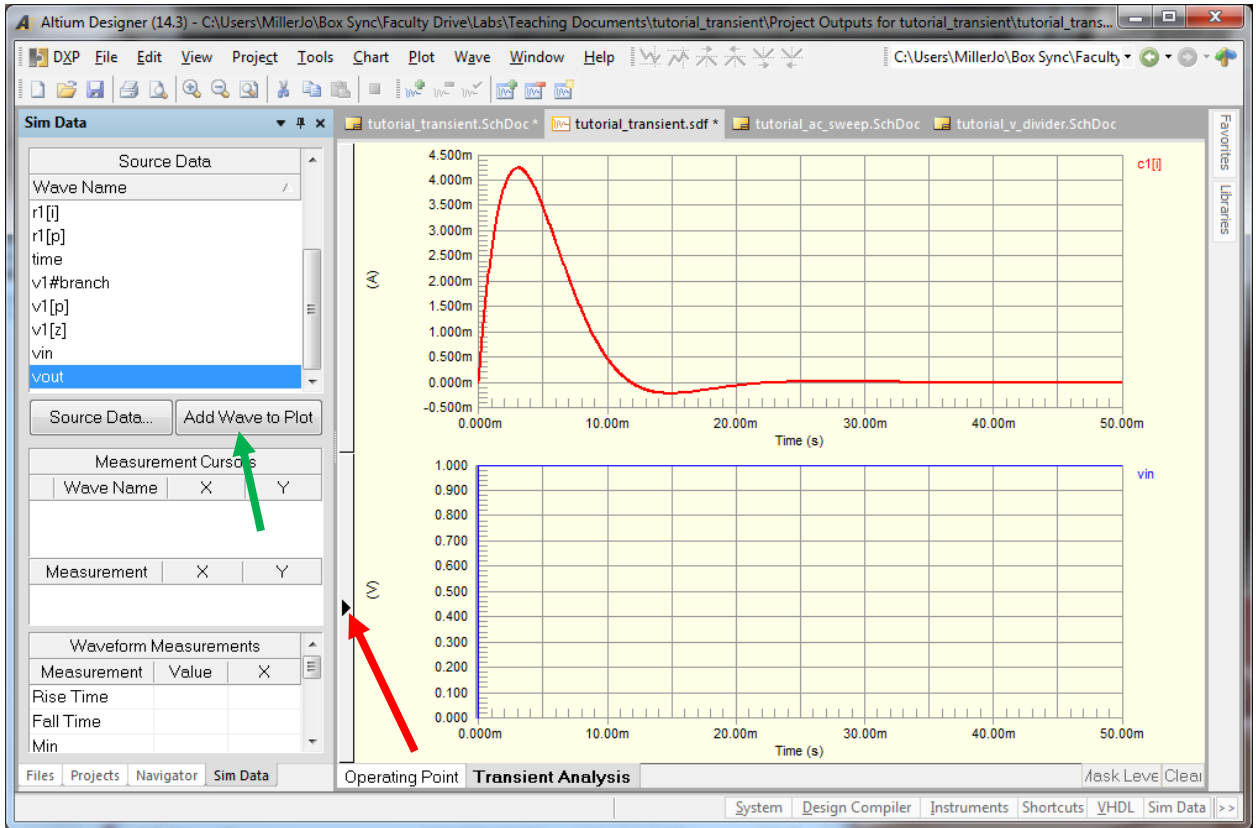

You should now have both Vin and Vout on the same plot.

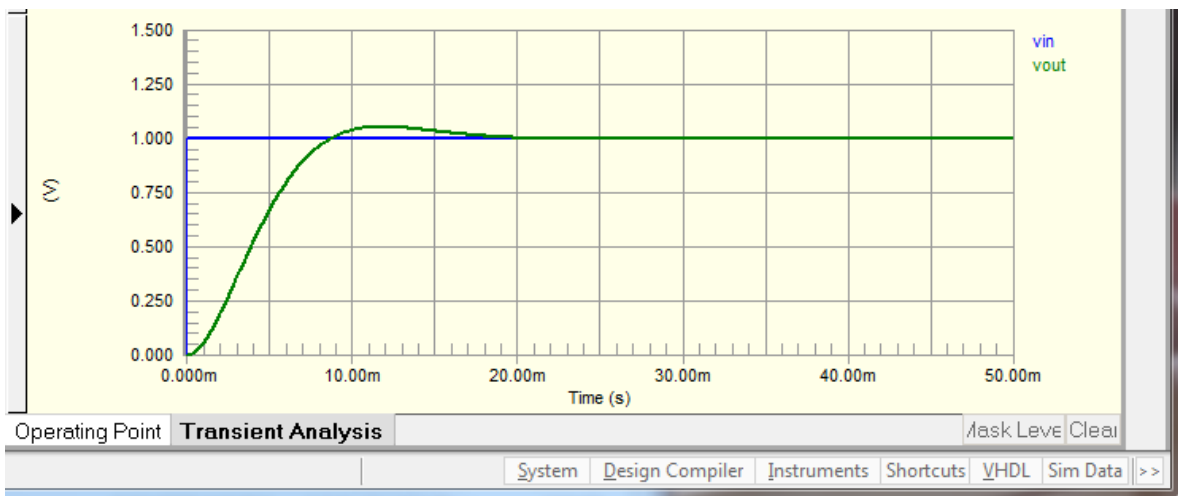

13. We can also make measurements on these waveforms. Click the name “vout” on the right side of the plot (red arrow). This selects just that signal or “wave.” Go to Wave → Cursor A and Cursor B to turn on both cursors. You should now see measurements in the Sim Data panel, as well as on the bottom of the chart (purple arrow).

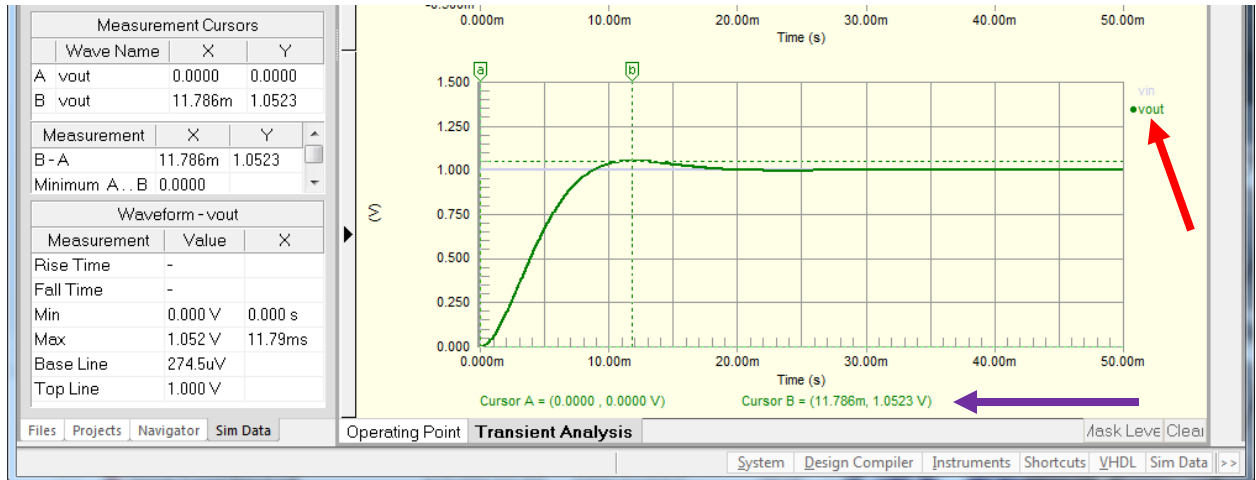

## AC Phasor/Fourier Analysis (Sinusoidal Steady-state)

The transient analysis simulation in Altium is not limited to step functions. Any continuous function can be applied as the input. This is simply a matter of changing the input source. In addition, there is a feature for doing Fourier or phasor analysis of sinusoidal steady-state inputs.

14. Create a new project and copy your circuit. Replace the VPWL source with a **VSIN** source.

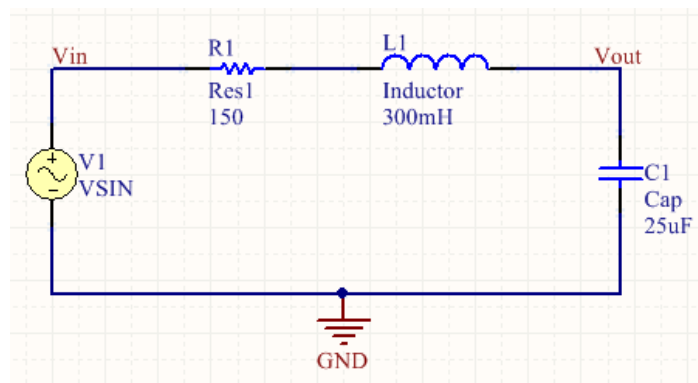

15. We need to setup the source, just like we did before in transient simulation. Double-click the source to open the Properties dialog. Click the **Edit** button in the Models section (lower right).



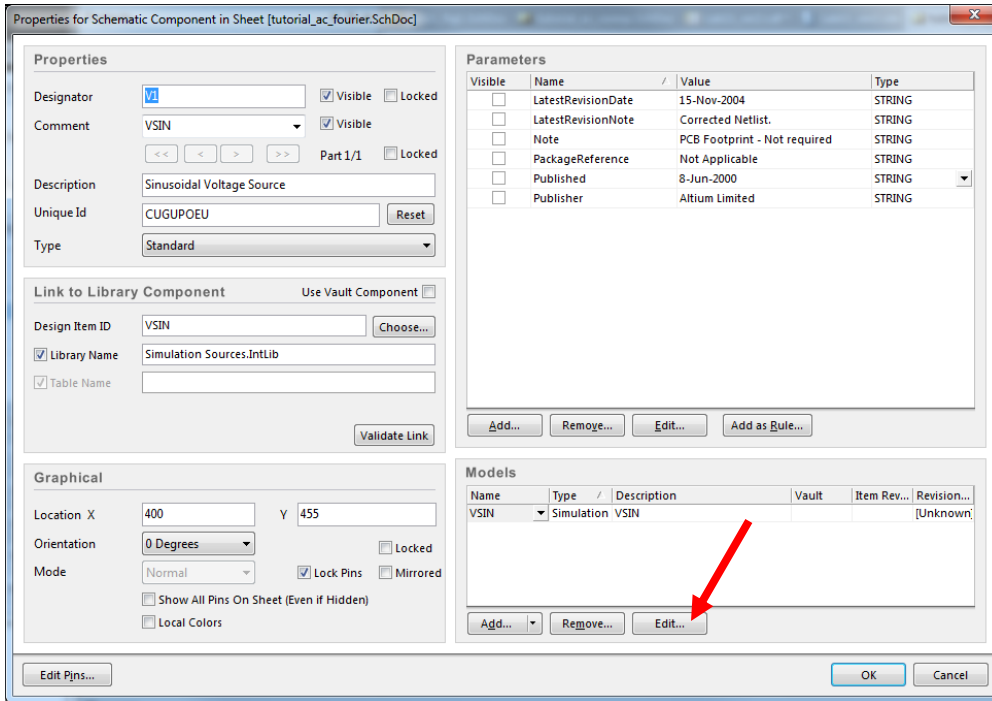

16. This brings up a second dialog. Click the **Parameters** tab (red arrow). You should have the dialog below. You can edit the table here or check the “Component parameter” box to display them on the schematic (where you can edit them directly). For this example, only the Frequency will be displayed on the schematic, and the other properties we will leave as their default values.

**Note:** The Transient and Fourier analyses use the last 6 parameters (from Offset downward).

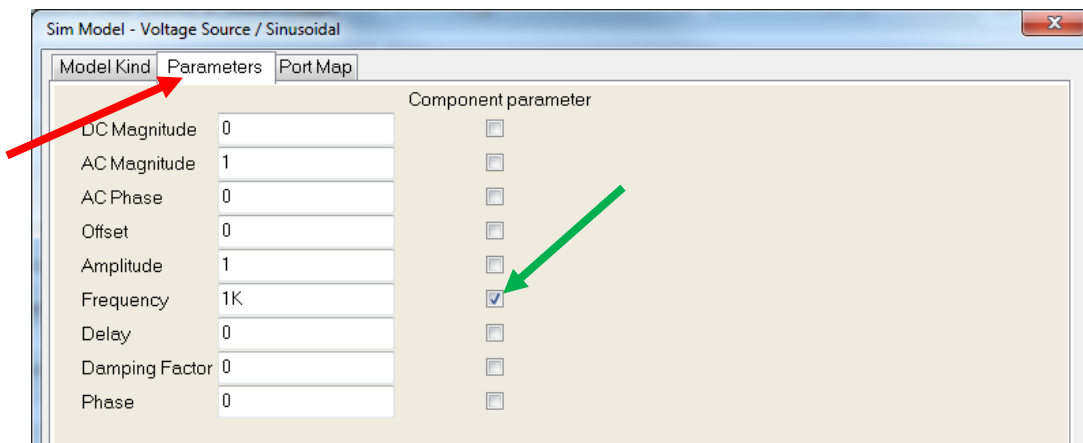

17. Change the frequency to 200 Hz. Note that the unit label “Hz” is not required, but without it, it’s not clear to which parameter that value corresponds. **DO NOT put a space between the number and the unit!** (Altium may still partially simulate but will display an error.)

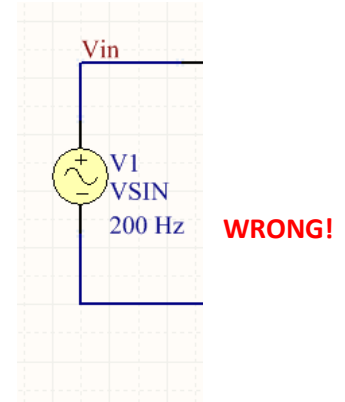
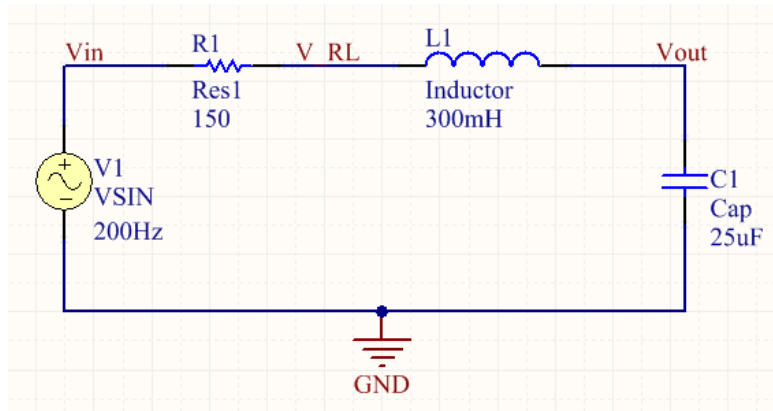

18. Click the simulation setup icon. Be sure the “Transient Analysis” box is checked, as we are still using that simulation type. Click on **Transient Analysis** to bring up its options. Again, uncheck the “Use Transient Defaults” box. Check the “Enable Fourier” box. This will perform the Fourier/phasor analysis in addition to the transient simulation. Set the Fundamental Frequency to the same frequency as your source (200 Hz) and the Number of Harmonics to 4. (The meaning of this setting will be discussed shortly.) Also, set the Stop Time to 20 ms.

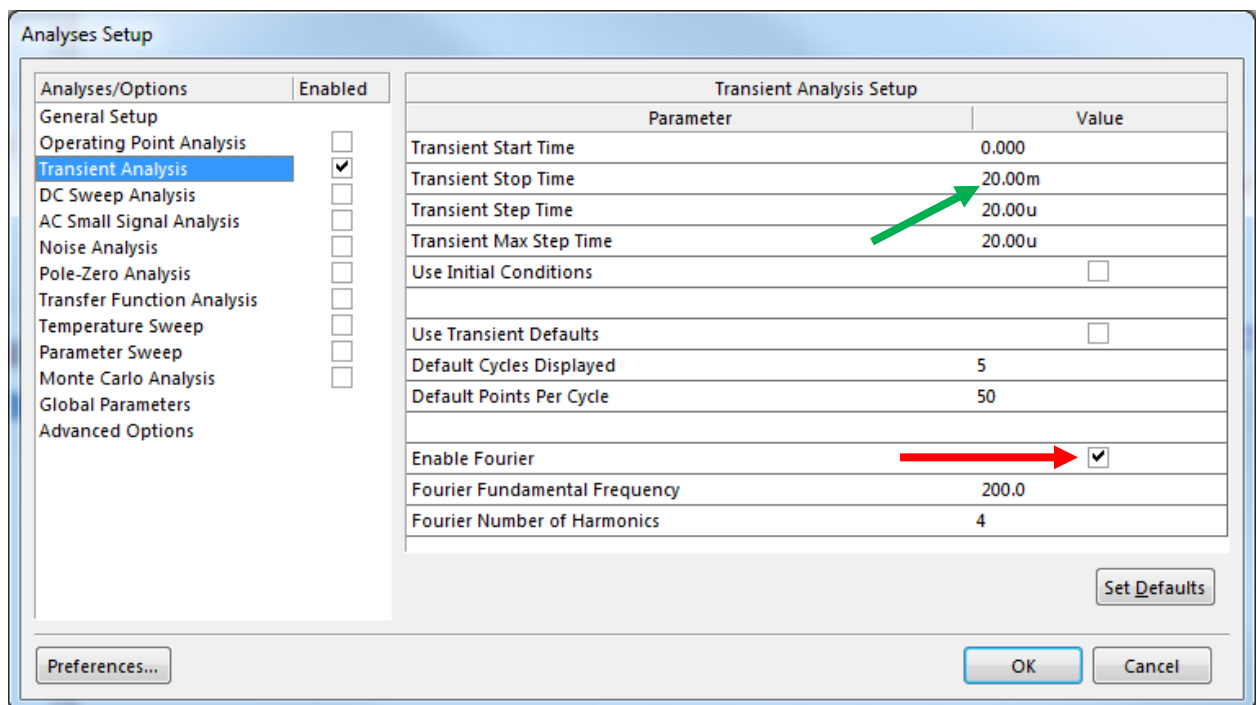

19. Run the simulation. You should get two (2) new documents that appear as tabs at the top: the simulation waveforms (.sdf) [red arrow] and a text document listing the phasor values at each node (.sim) [green arrow]. The simulation document is split further by the various types of simulation, shown as tabs at the bottom of the screen. Fourier Analysis (purple arrow) should open by default when you select that document (top tab).

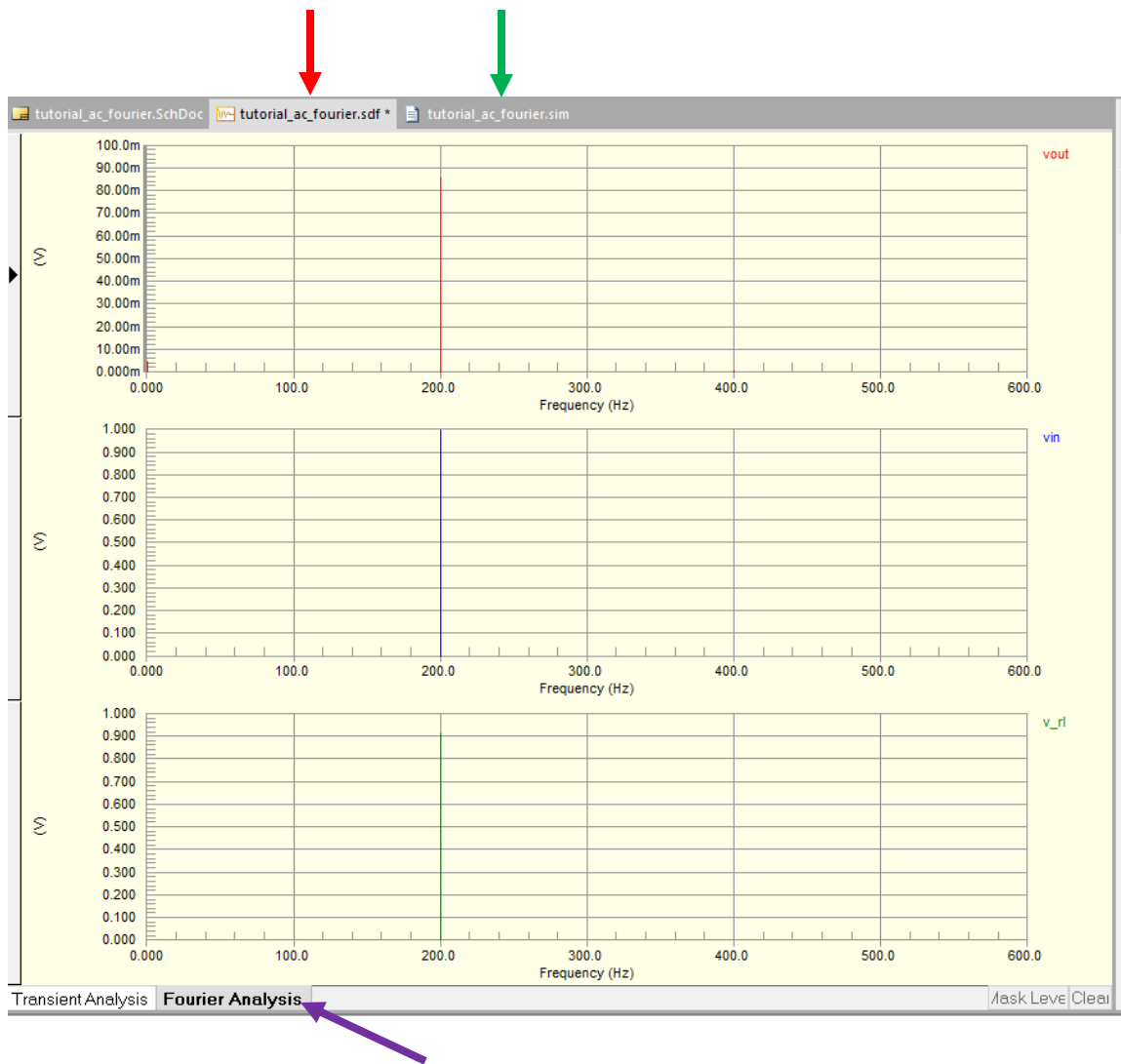

This is a graphical depiction of the amplitude (magnitude) of the node voltage at various frequencies. The number of points (bars, really) shown here depends on the number of “harmonics” we entered in the simulation setup. Altium counts harmonics starting at 0. The harmonic frequency is given by multiplying the fundamental by the harmonic number. So, 0 Hz is the zero-th harmonic, the fundamental (200 Hz in this example) is the first, and then they increase as multiples of the fundamental from there. So for this example, the second is 400 Hz, and the third is 600 Hz. (Other quantities could be plotted as well, like phase, etc. This is not shown.)

20. The other document (.sim) is a listing of the phasor voltage at each node (blue arrow). It shows magnitude (green) and phase in radians (purple) for each harmonic frequency value (red).

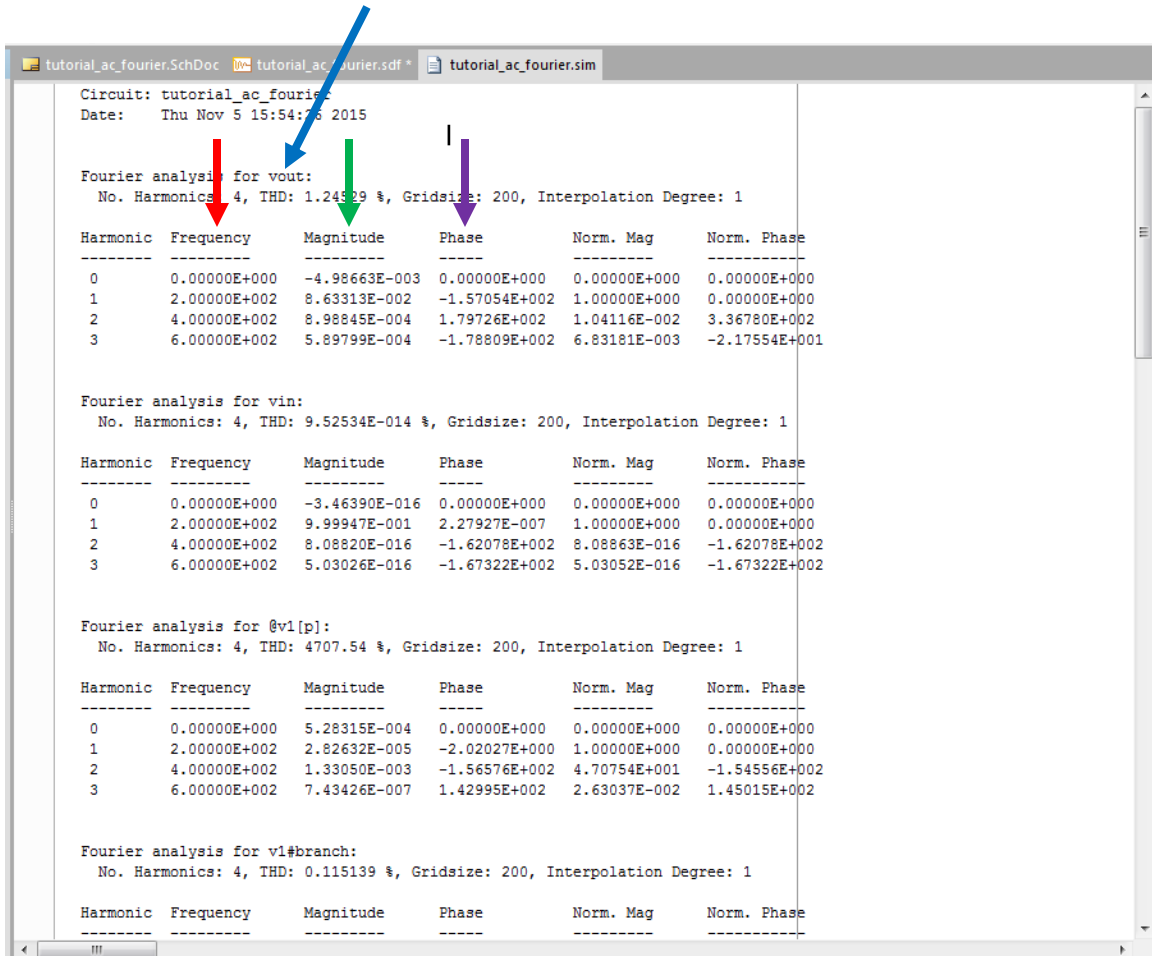

## AC Sweep Simulation

21. Use the same circuit and source (VSIN) as in the previous (AC Fourier) section.

**Note:** AC sweep uses the first 3 parameters of the VSIN model (DC Mag, AC Mag, and AC Phase). Frequency is specified as part of the simulation setup (see next step).

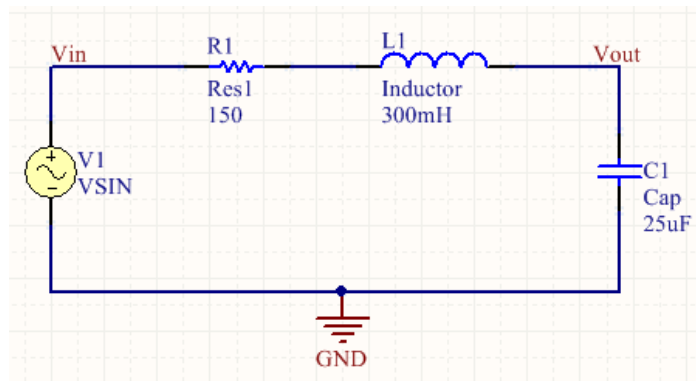

22. Click the simulation setup icon. Check the **AC Small Signal Analysis** box (sometimes referred to as an “AC sweep”) and click on the name. Setup the analysis as shown below. (Note: You can run all of the various simulations simultaneously if you want.)

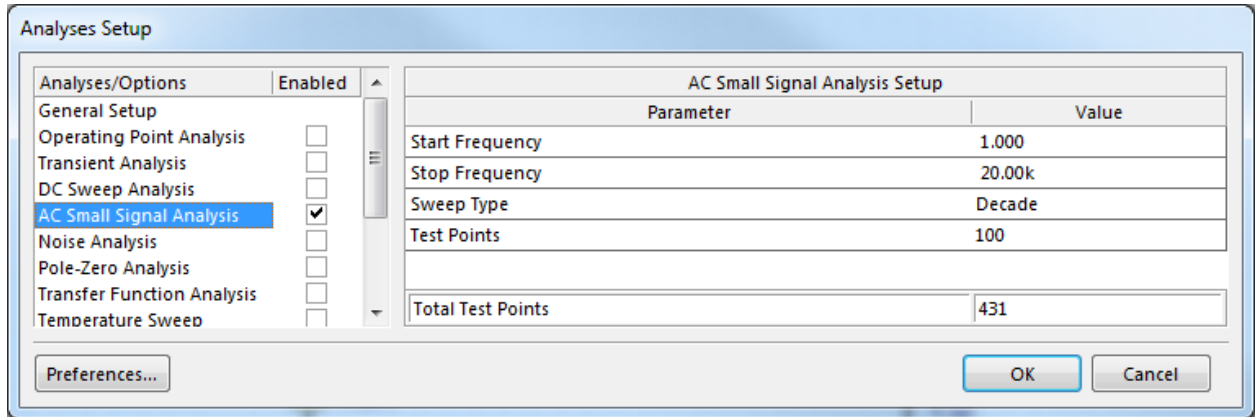

23. Your result should look like this. This plot shows how the voltages vary as frequency changes.

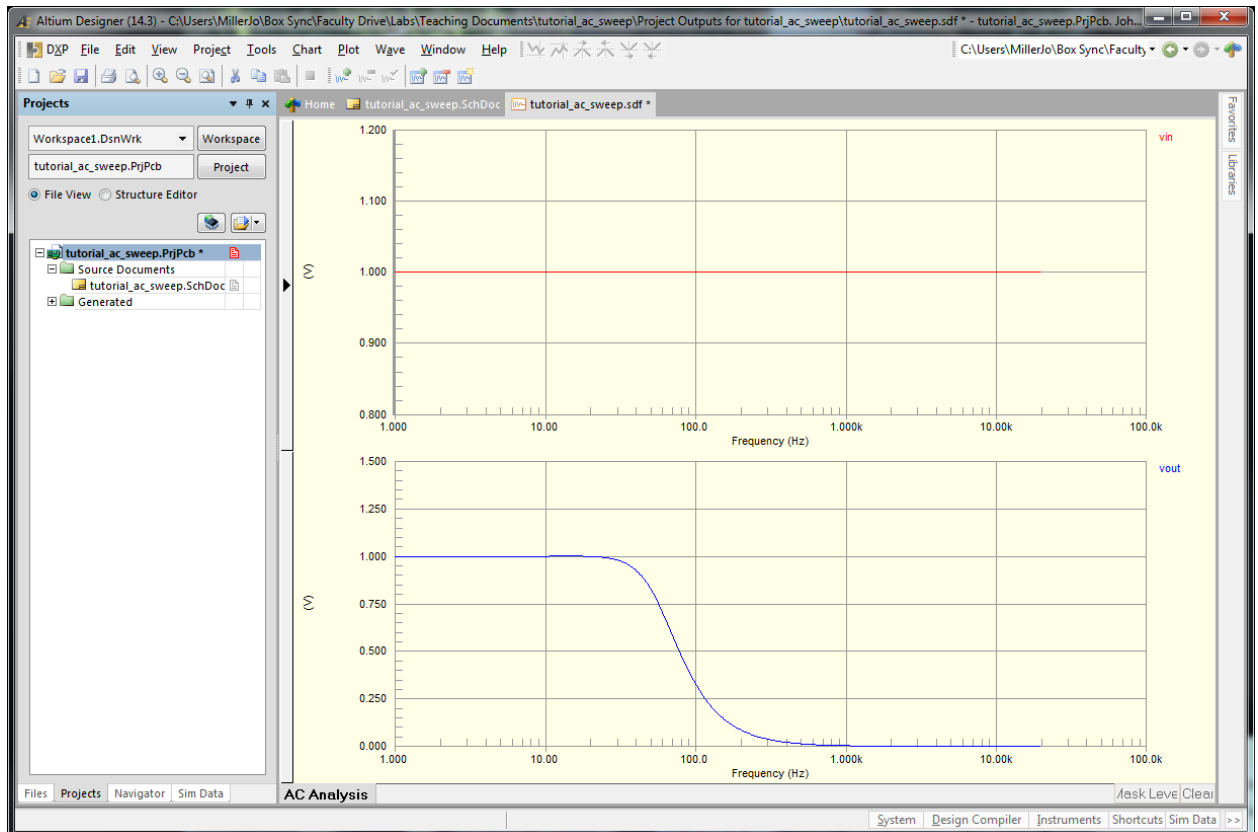

24. Very often when doing AC sweep analysis, we are looking for a Bode plot. This is a plot of the magnitude (in dB) and phase of the ratio of output-to-input. Altium can do this for us in a few clicks. Click on the name of each wave and select **Remove Wave** to delete it from the plot (should have two empty plots left).
25. Right-click the top plot and choose **Add Wave to Plot...**. In the dialog, select **Magnitude (dB)** and create the expression "vout/vin" either by typing it directly or clicking the corresponding elements in the dialog (i.e. click "vout", then "/", then "vin"). Click Create.

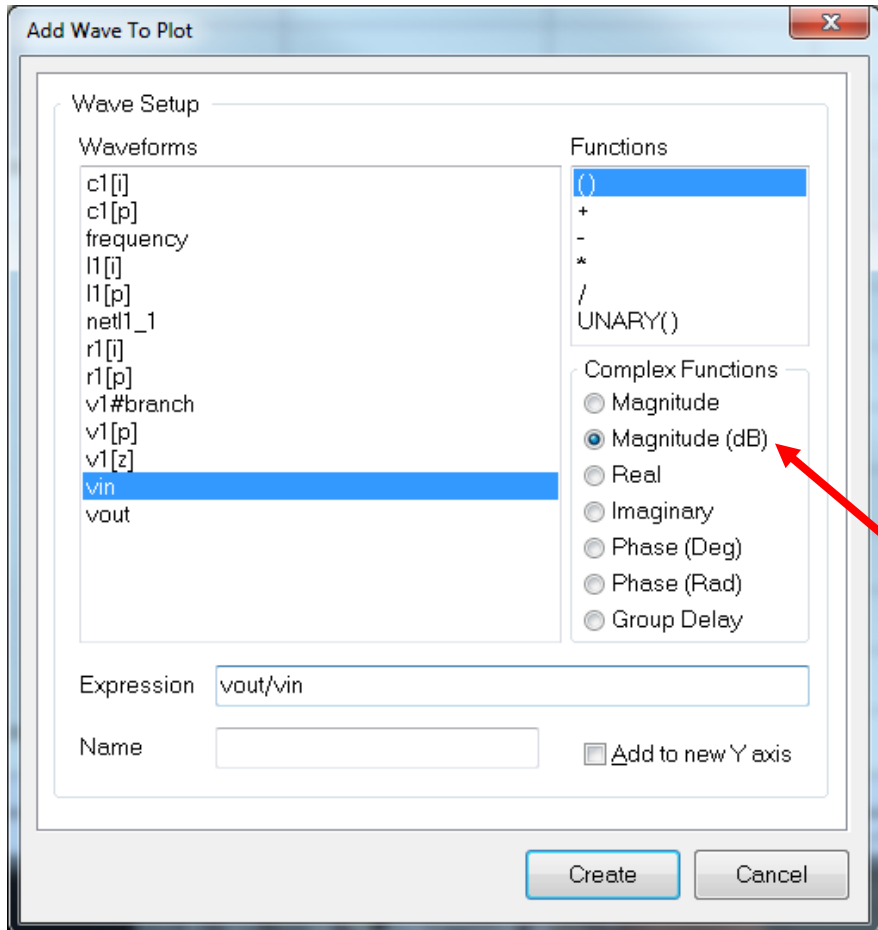

26. Do the same thing in the bottom plot, but choose **Phase (Deg)** (expression is still “vout/vin”). You should end up with the following.

