



Интернет вещей

Конечные автоматы
FSM

Конечные автоматы- FSM

Конечный автомат — это абстракция, описывающая решение задачи. Он определяет поведение системы в виде механизма, который изменяет свое состояние в ответ на входные данные системы и производит соответствующие выходные данные.

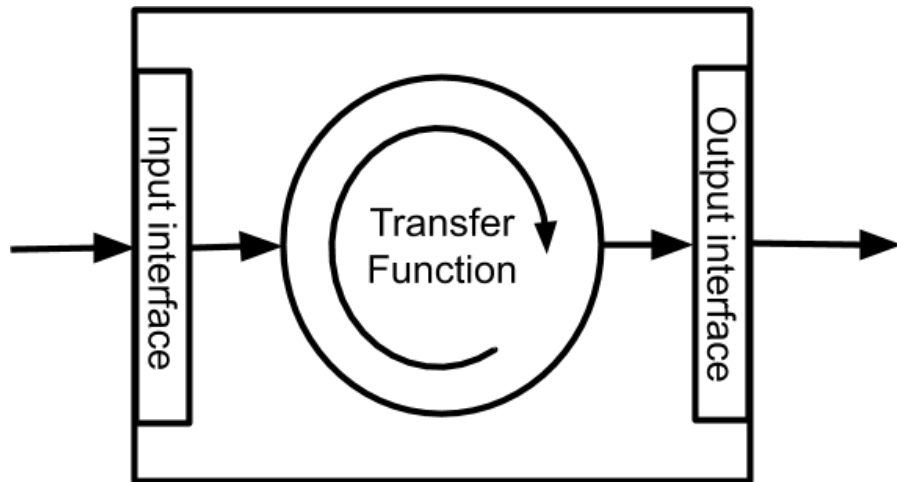

1. Конечное число состояний, одно определяется как начальное.
2. Конечное количество записей в системе.
3. Конечное количество выходов.
4. Передаточная функция для переходов между состояниями.
5. Функция определения выхода.

En: Finite State Mashine

Конечные автоматы - Диаграммы

«Конечный автомат» — это модель поведения, состоящая из состояний, переходов и действий.

- **Состояние** хранит информацию о прошлом, то есть отражает изменения на входе от инициализации системы до настоящего момента.
- **Переход** указывает на изменение состояния и описывается **условием**, которое необходимо выполнить, чтобы вызвать переход.
- **Действие** — это описание действия, которое должно быть выполнено в определенное время.

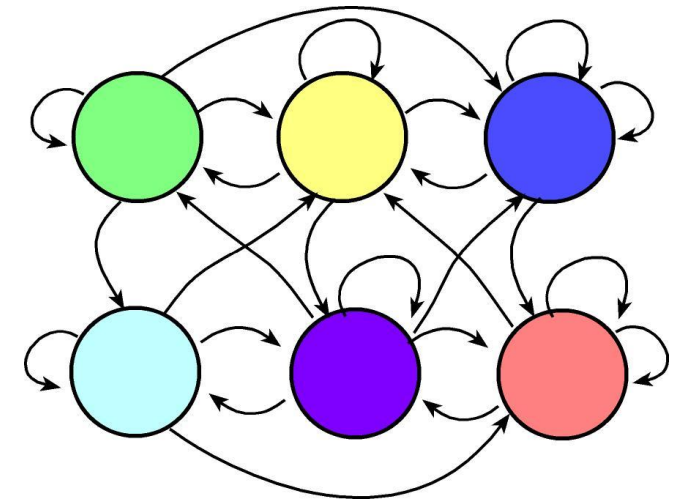
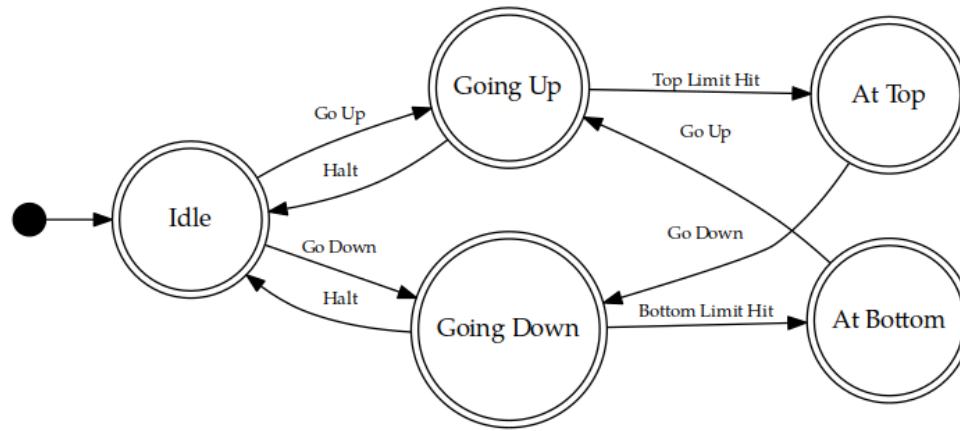
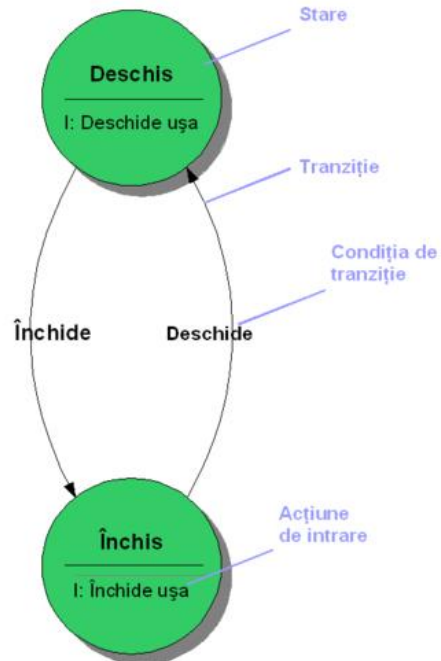

Конечные автоматы – Mealy vs Moore

Moore Machine

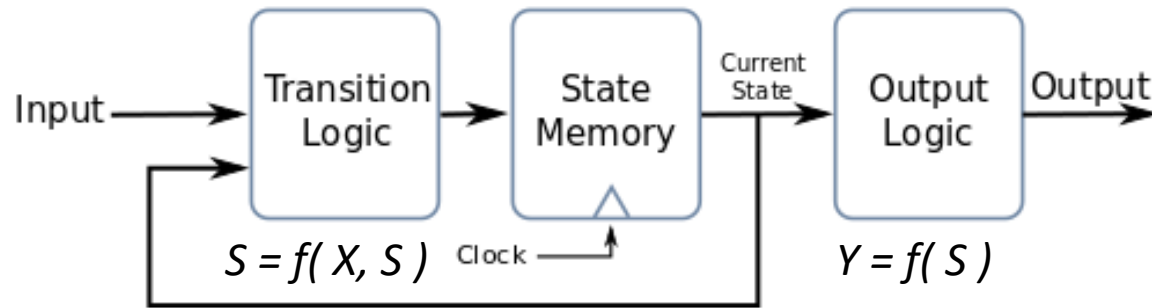

Mealy Machine

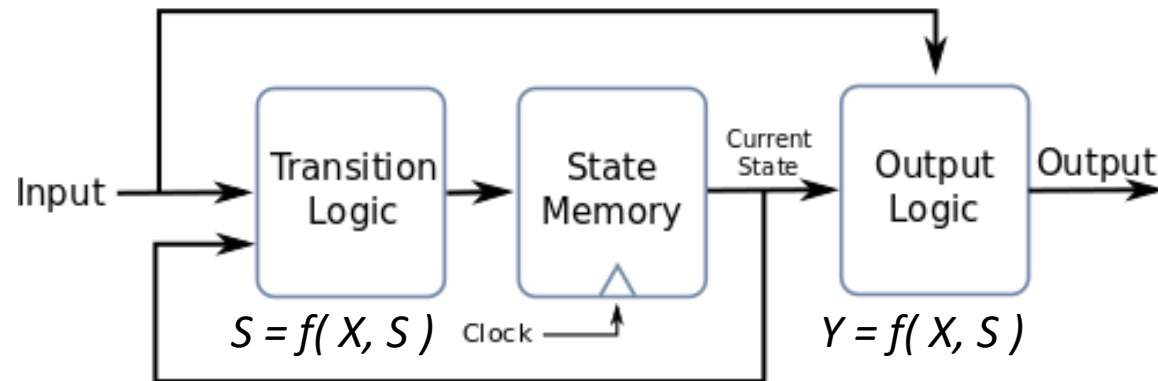

Moore Machine

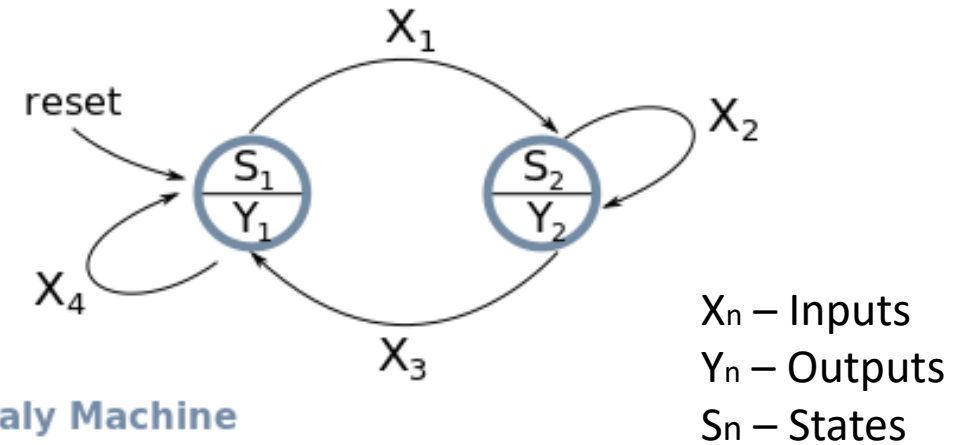

Mealy Machine

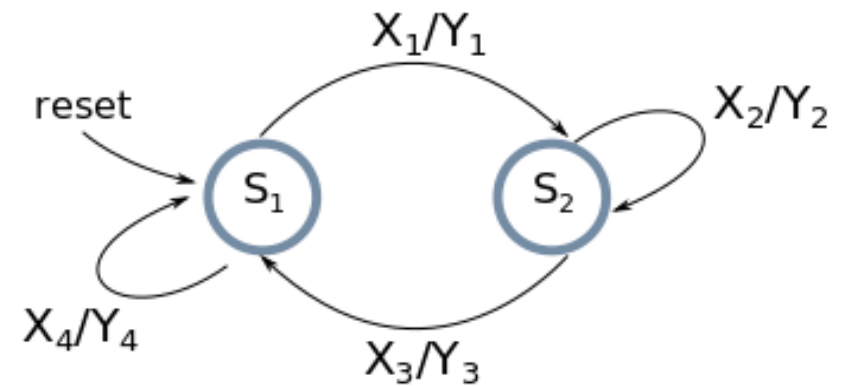

Конечные автоматы - Оценка

Automat Moore

$NextState = f(Input, CurrentState)$

$Output = g(CurrentState)$

TaskMooreFSM(){

1. **Evaluare ieşiri**, dependente **doar** de **Starea curenta**
 2. **Reţinere** perioada definita de stare
 3. **Colectare Intrări**
 4. **Evaluare Stare următoare** dependenta de **Intrare** si **Stare curentă**
- }**

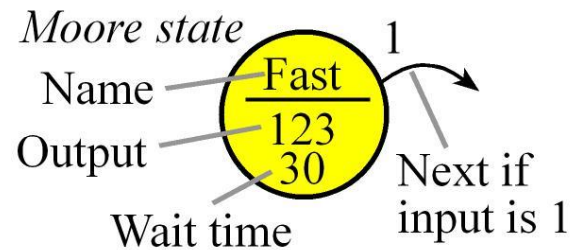

Automat Mealy

$NextState = f(Input, CurrentState)$

$Output = h(Input, CurrentState)$

TaskMealyFSM()

1. **Reţinere** perioada definita de stare
 2. **Colectare Intrări**
 3. **Evaluare ieşiri**, dependente de **Intrare** si **Starea curentă**
 4. **Evaluare Stare următoare** dependenta de **Intrare** si **Stare curentă**
- }**

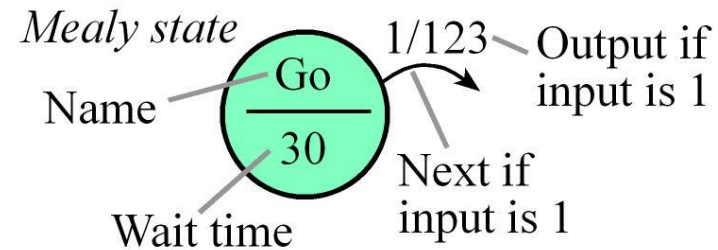

Конечные автоматы – Button/Led : FSM design

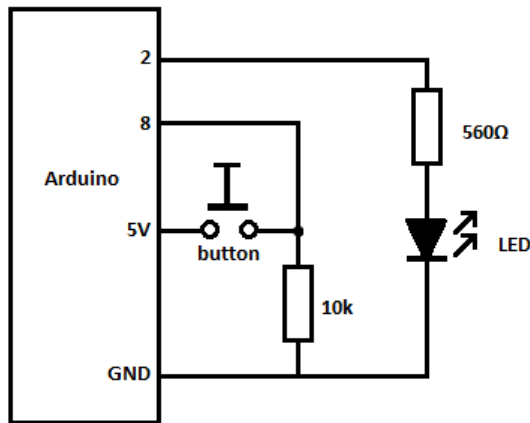
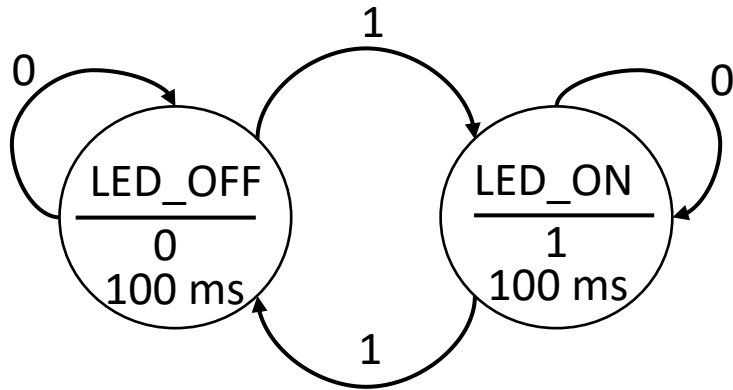

Num	Name	Out	Delay	In = 0	In = 1
0	LED_OFF	0	100 ms	LED_OFF	LED_ON
1	LED_ON	1	100 ms	LED_ON	LED_OFF

```

#define LED_OFF_STATE 0
#define LED_ON_STATE 1

struct State {
    unsigned long Out; // Led State
    unsigned long Time; // delay in 10ms units
    unsigned long Next[2]; // next state for inputs 0,1
};
typedef const struct State STyp;

STyp FSM[2]={
    {0,10,{LED_OFF_STATE, LED_ON_STATE }},
    {1,10,{LED_ON_STATE, LED_OFF_STATE }}
};
  
```

Конечные автоматы – Button/Led : FSM Controller

```
#define LED_PIN 2
#define BUTTON_PIN 8

#define LED_OFF_STATE 0
#define LED_ON_STATE 1

struct State {
    unsigned long Out;    // Led State
    unsigned long Time;  // delay in 10ms units
    unsigned long Next[2]; // next state for inputs 0,1
};
typedef const struct State STyp;

STyp FSM[2]={
    {0,10,{LED_OFF_STATE, LED_ON_STATE }},
    {1,10,{LED_ON_STATE, LED_OFF_STATE }}
};

int FSM_State = LED_OFF_STATE;

void setup()
{
    // Init Button
    pinMode(BUTTON_PIN, INPUT);
    // Init LED
    pinMode(LED_PIN, OUTPUT);
    // Init Initial State
    FSM_State = LED_OFF_STATE;
}
```

TaskMooreFSM(){

1. *Evaluare Ieșiri*, dependente doar de *Starea curenta*
 2. *Reținere* perioada definita de stare
 3. *Colectare Intrări*
 4. *Evaluare Stare următoare* dependenta de *Intrare* si *Stare curentă*
- }*

```
// The loop function is called in an endless loop
void loop()
{
    // 1. Output Based on current state
    int output = FSM[FSM_State].Out;
    digitalWrite(LED_PIN, output);

    // 2. wait for time relevant to state
    delay(FSM[FSM_State].Time * 10);

    // 3. Get Input
    int input = digitalRead(BUTTON_PIN);

    // 4. Change state based on input and current state
    FSM_State = FSM[FSM_State].Next[input];
}
```

Конечные автоматы – Semafor : FSM design

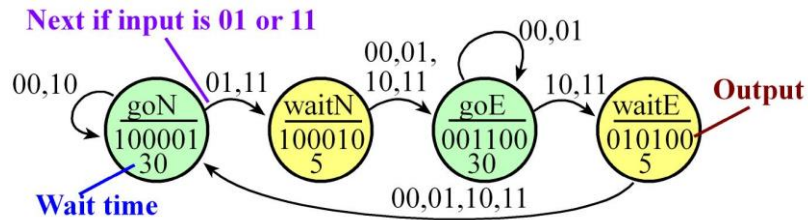

Num	Name	Out	Delay	In = 0	In = 1	In = 2	In = 3
0	goN	100 001	30 s	goN	waitN	goN	waitN
1	waitN	100 010	5 s	goE	goE	goE	goE
2	goE	001 100	30 s	goE	goE	waitE	waitE
3	waitE	010 100	5 s	goN	goN	goN	goN

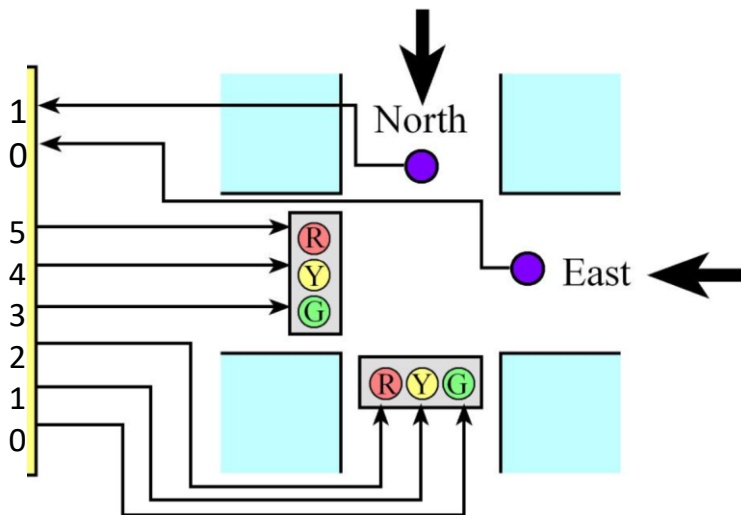

```
struct State {
    unsigned long Out; // 6-bit pattern to output
    unsigned long Time; // delay in 10ms units
    unsigned long Next[4]; // next state for inputs 0,1,2,3
};
```

```
typedef const struct State STyp;
```

```
#define goN 0 // 0b00
#define waitN 1 // 0b01
#define goE 2 // 0b10
#define waitE 3 // 0b11
```

```
STyp FSM[4]={
    {0b100001, 3000, {goN, waitN, goN, waitN }},
    {0b100010, 500, {goE, goE, goE, goE }},
    {0b001100, 3000, {goE, goE, waitE, waitE }},
    {0b010100, 500, {goN, goN, goN, goN }}}
```

Конечные автоматы – Semafor: FSM Controller

```
#define NORTH_PIN 1
#define EAST_PIN 2
#define EAST_RED_PIN 3
#define EAST_YELLOW_PIN 4
#define EAST_GREEN_PIN 5
#define NORTH_RED_PIN 6
#define NORTH_YELLOW_PIN 7
#define NORTH_GREEN_PIN 8
#define goN 0 // 0b00
#define waitN 1 // 0b01
#define goE 2 // 0b10
#define waitE 3 // 0b11

struct State {
    unsigned long Out; // 6-bit pattern to output
    unsigned long Time; // delay in 10ms units
    unsigned long Next[4]; // next state for inputs 0,1,2,3
};
typedef const struct State STyp;

STyp FSM[4]={
    {0b100001, 3000, {goN, waitN, goN, waitN }},
    {0b100010, 500, {goE, goE, goE, goE }},
    {0b001100, 3000, {goE, goE, waitE, waitE }},
    {0b010100, 500, {goN, goN, goN, goN }}
};
int FSM_State = goN;

void setup() {
    // Init Button
    pinMode(NORTH_PIN, INPUT);
    pinMode(EAST_PIN, INPUT);
    // Init LED
    pinMode(EAST_RED_PIN, OUTPUT);
    pinMode(EAST_YELLOW_PIN, OUTPUT);
    pinMode(EAST_GREEN_PIN, OUTPUT);
    pinMode(NORTH_RED_PIN, OUTPUT);
    pinMode(NORTH_YELLOW_PIN, OUTPUT);
    pinMode(NORTH_GREEN_PIN, OUTPUT);
    // Init Initial State
    FSM_State = goN;
}
```

```
int GetInput(void) {
    int northButton = digitalRead(NORTH_PIN);
    int eastButton = digitalRead(EAST_PIN);
    if (northButton && eastButton)
        return 0b11;
    else if (northButton)
        return 0b10;
    else if (eastButton)
        return 0b01;
    else
        return 0b00;
}

void SetOutput(int out) {
    int ledState;
    ledState = (out & (1 << 5)) ? HIGH : LOW;
    digitalWrite(EAST_RED_PIN, ledState);
    ledState = (out & (1 << 4)) ? HIGH : LOW;
    digitalWrite(EAST_YELLOW_PIN, ledState);
    ledState = (out & (1 << 3)) ? HIGH : LOW;
    digitalWrite(EAST_GREEN_PIN, ledState);
    ledState = (out & (1 << 2)) ? HIGH : LOW;
    digitalWrite(NORTH_RED_PIN, ledState);
    ledState = (out & (1 << 1)) ? HIGH : LOW;
    digitalWrite(NORTH_YELLOW_PIN, ledState);
    ledState = (out & (1 << 0)) ? HIGH : LOW;
    digitalWrite(NORTH_GREEN_PIN, ledState);
}

// The loop function is called in an endless loop
void loop() {
    // 1. Output Based on current state
    int output = FSM[FSM_State].Out;
    SetOutput(output);
    // 2. wait for time relevant to state
    delay(FSM[FSM_State].Time * 10);
    // 3. Get Input
    int input = GetInput();
    // 4. Change state based on input and current state
    FSM_State = FSM[FSM_State].Next[input];
}
```

Handwritten red annotations:

- A red bracket groups the first four lines of the `GetInput()` function.
- A red bracket groups the last four lines of the `SetOutput()` function.
- A red bracket groups the last four lines of the `loop()` function.
- Handwritten red text: `00000001` with `x` marks under the last four bits.
- Handwritten red text: `if (0000000x) {` with a closing brace.

Конечные автоматы– Line Follow : FSM design

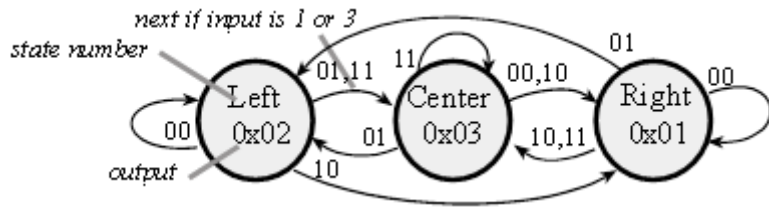

Num	Name	Out	Delay	In = 0	In = 1	In = 2	In = 3
0	Center	0x03	1 ms	Right	Left	Right	Center
1	Left	0x02	1 ms	Left	Center	Right	Center
2	Right	0x01	1 ms	Right	Left	Center	Center

```

struct State {
    unsigned long out;           // 2-bit output
    unsigned long delay;        // time to delay in 10ms
    unsigned long next[4];      // Next if 2-bit input is 0-3
};
typedef const struct State STyp;
  
```

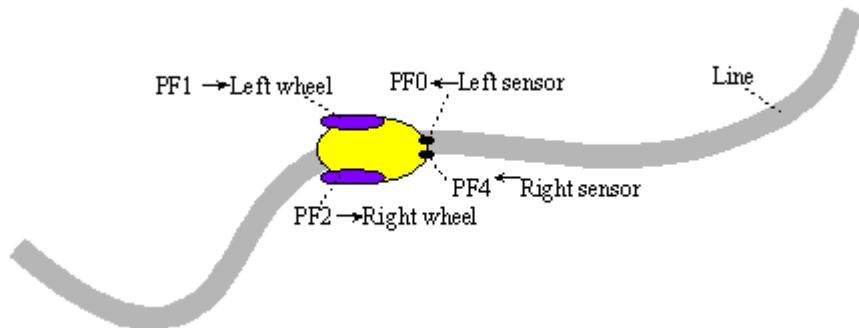

```

#define Center 0
#define Left 1
#define Right 2
STyp FSM[3]={
    {0x03, 1, { Right, Left, Right, Center }}, // Center
    {0x02, 1, { Left, Center, Right, Center }}, // Left
    {0x01, 1, { Right, Left, Center, Center }} // Right
};
  
```