



Интернет вещей

Устройства воздействия

Преобразователь
мощности

SMART HOME SYSTEM

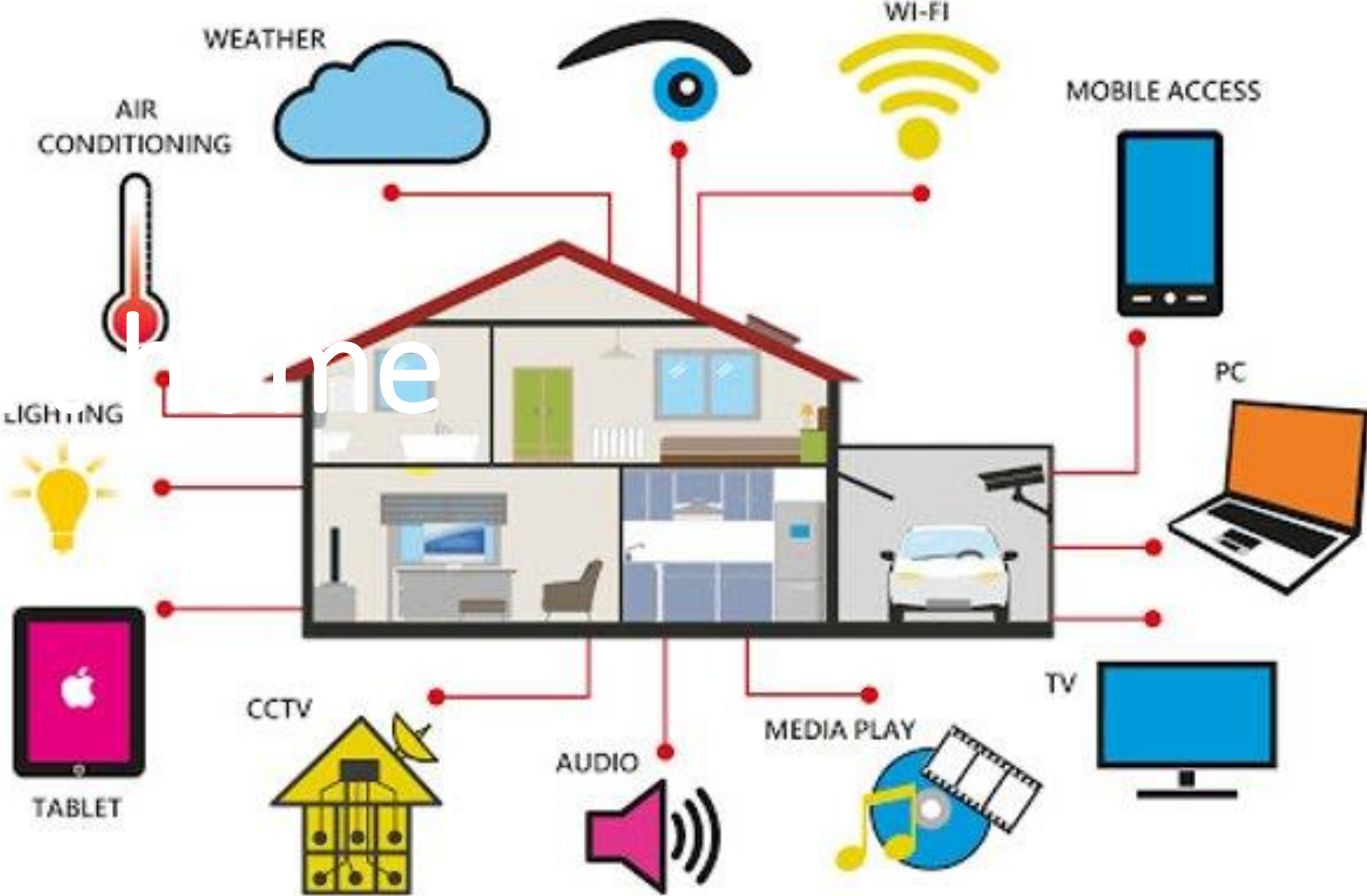

Типы взаимодействий

- Взаимодействие с пользователем
- **Взаимодействие с окружающей средой**
- Взаимодействие с устройствами(IoT)

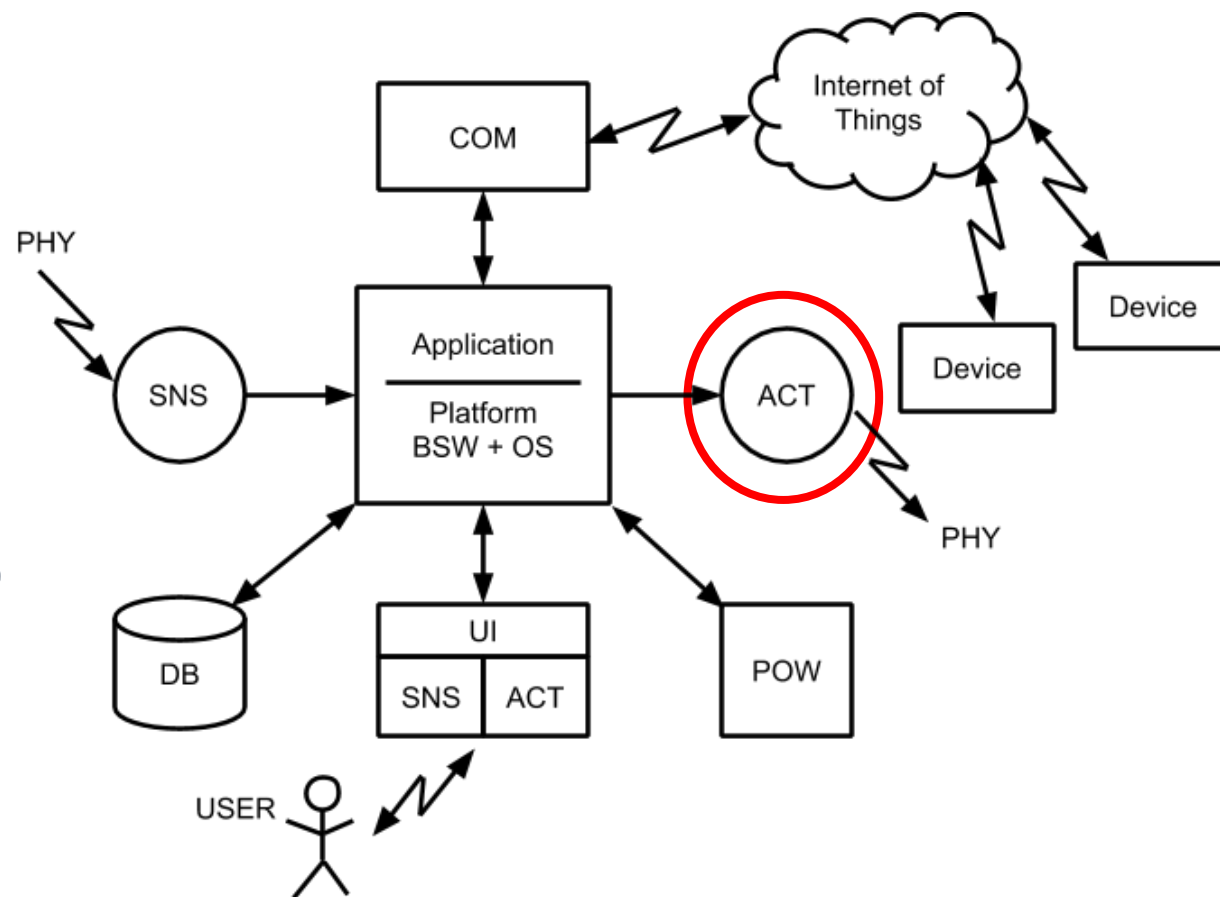

Устройства воздействия

Преобразует внутренний сигнал системы в воздействие на физическую среду.

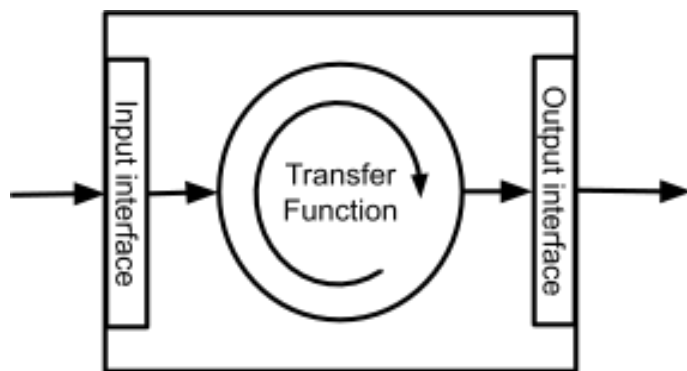
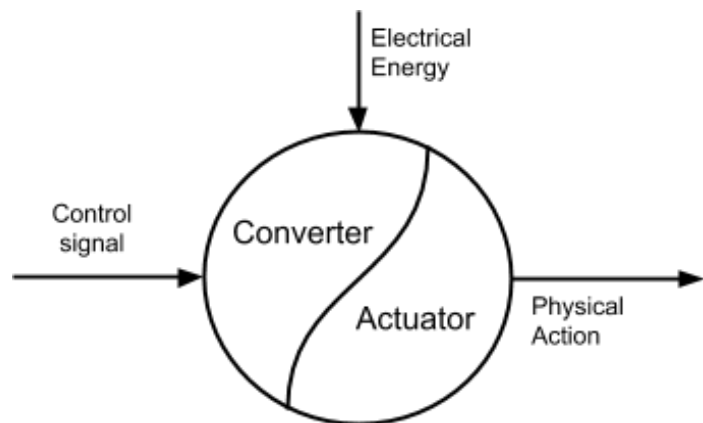

- Преобразователь - электрический управляющий сигнал в электрическую энергию, подаваемую на привод.
- Привод – электрическая энергия в действии



Преобразователь мощности

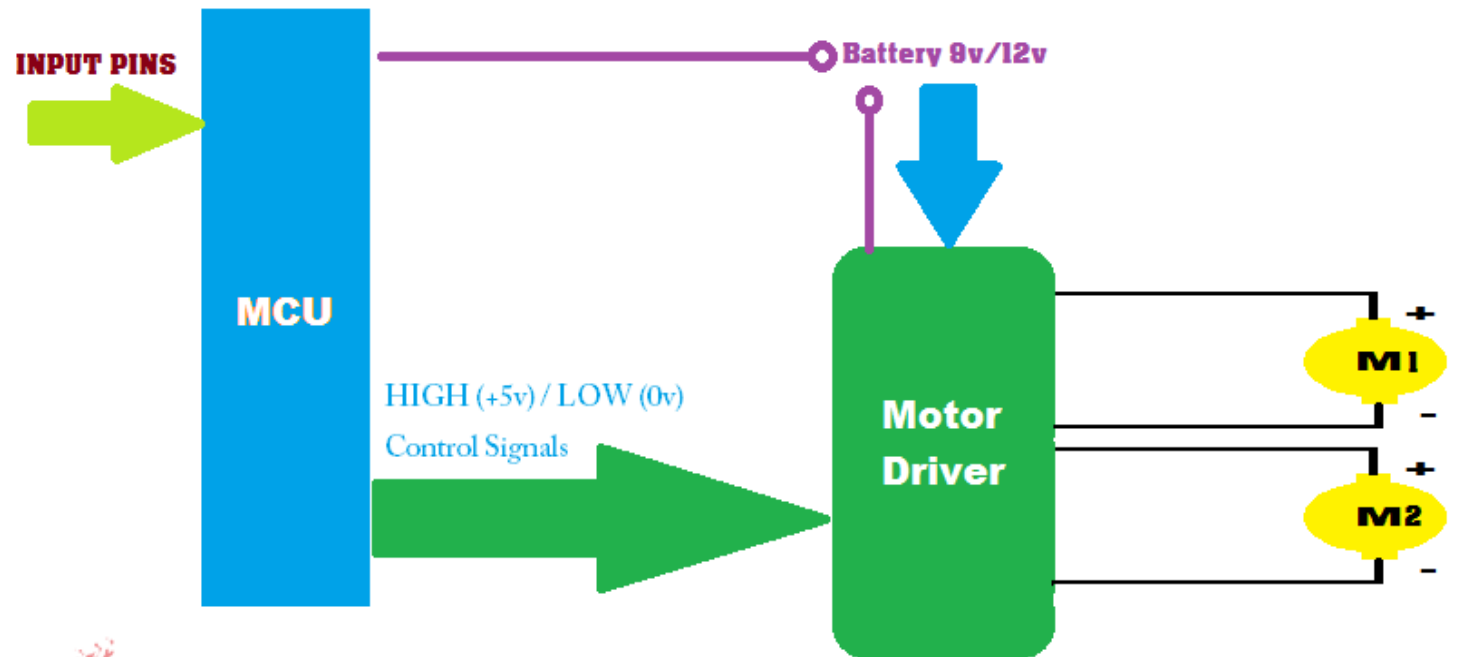
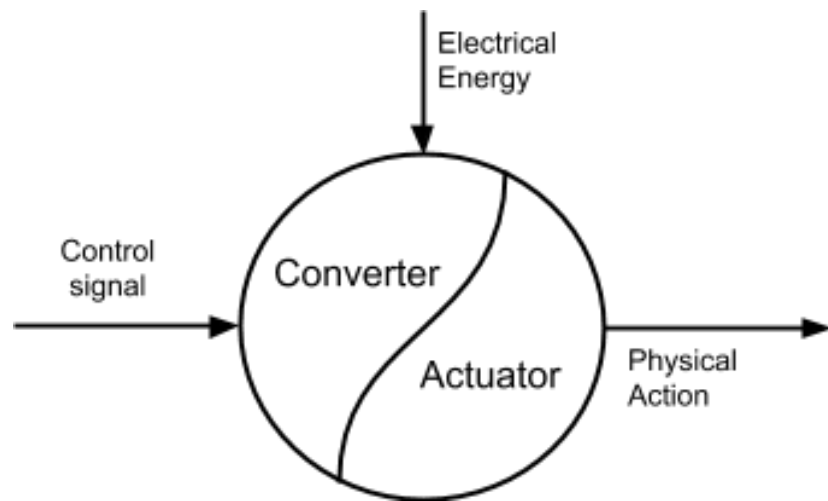

Преобразователь мощности - Реле

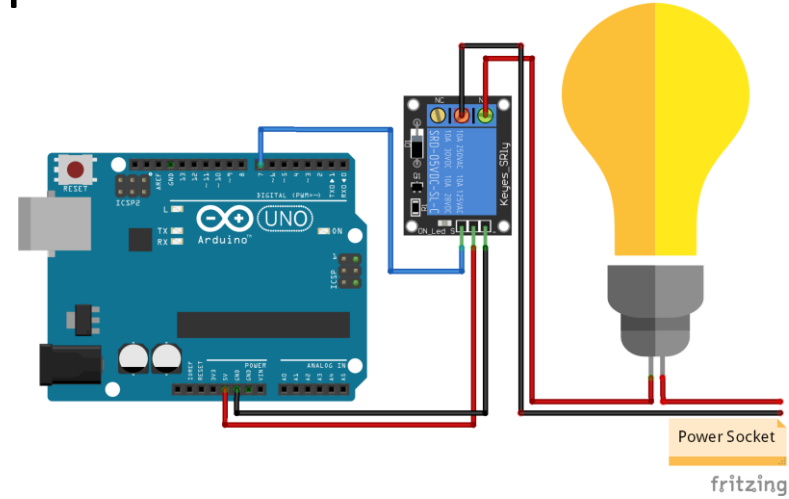
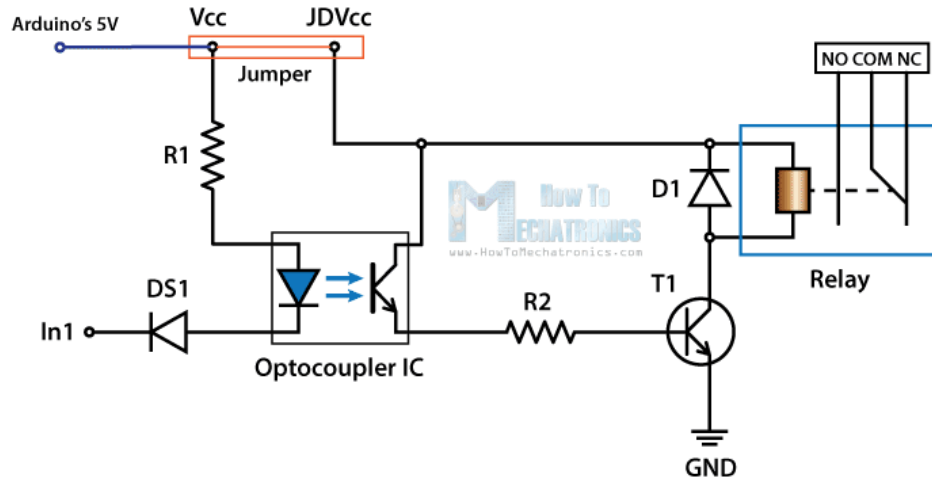

1 electromagnetic relay.

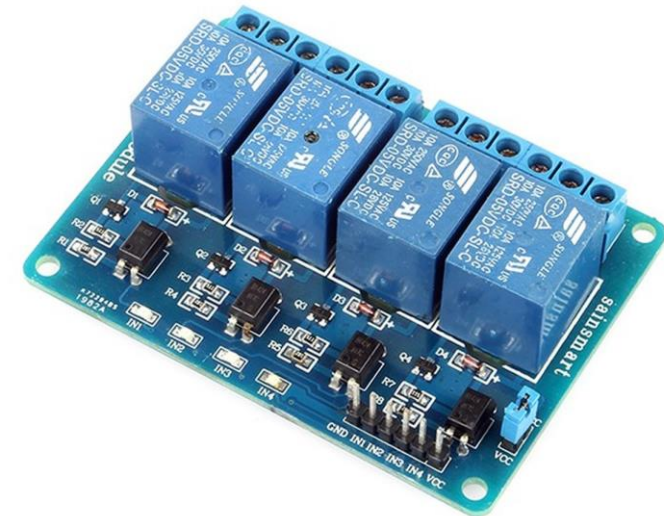
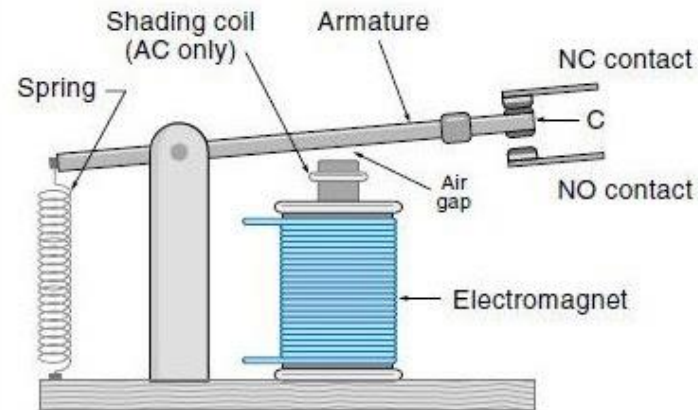

Транзистор — аналогии

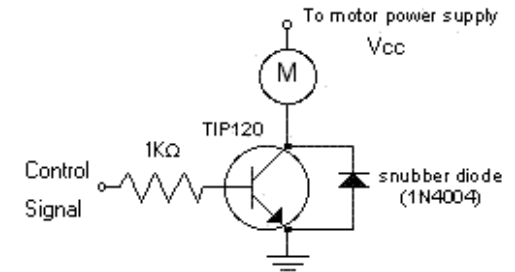
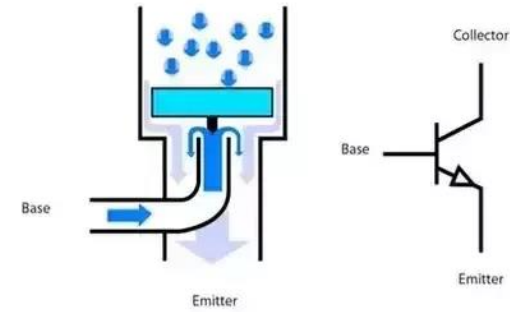
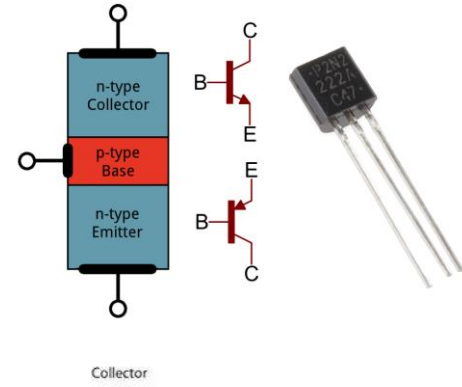
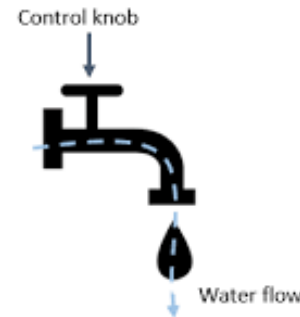
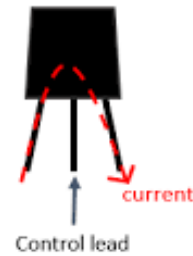
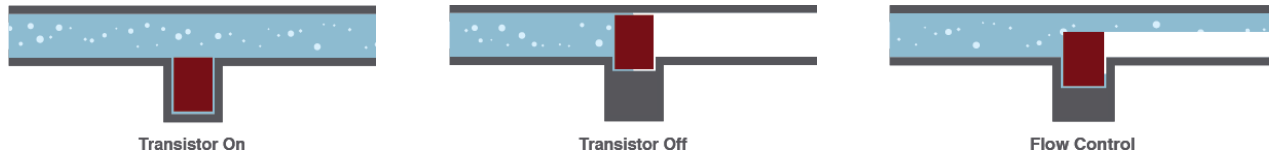
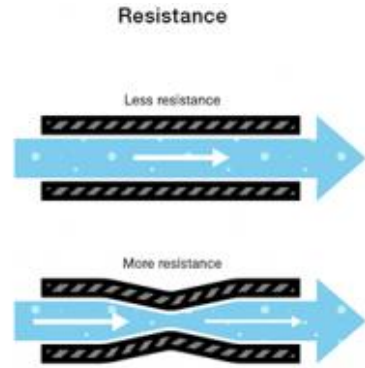
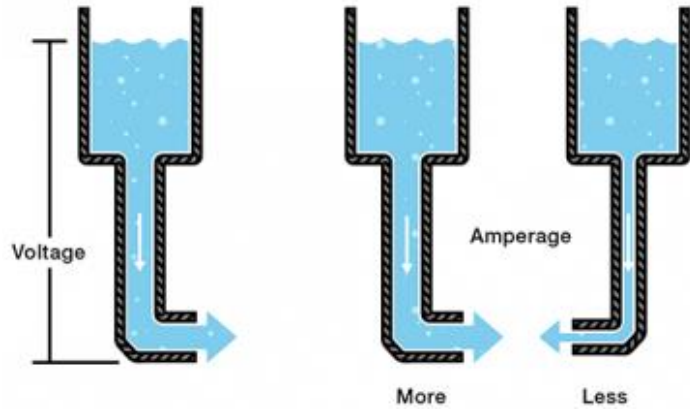

Преобразователь мощности - аналоговое управление

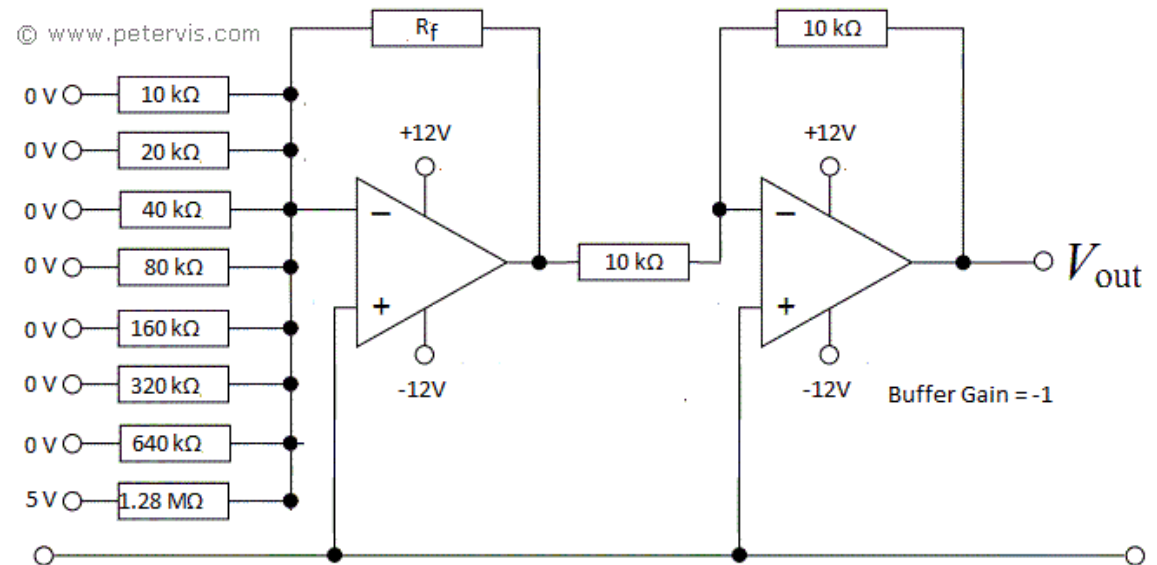
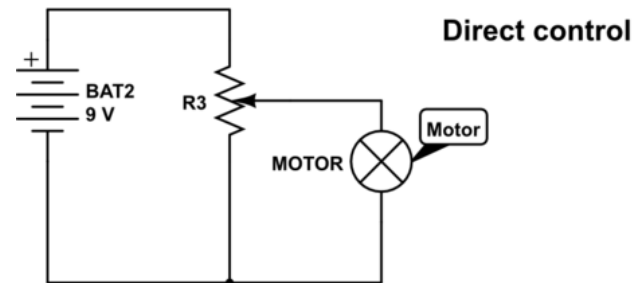
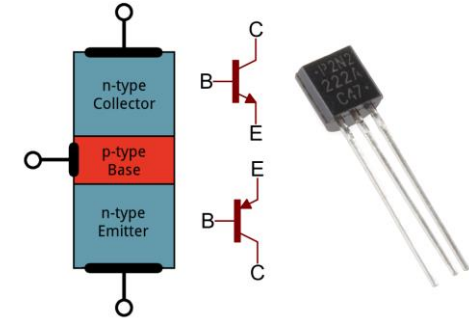
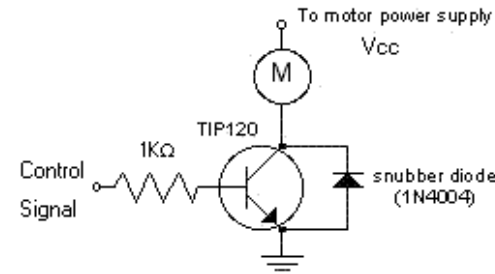
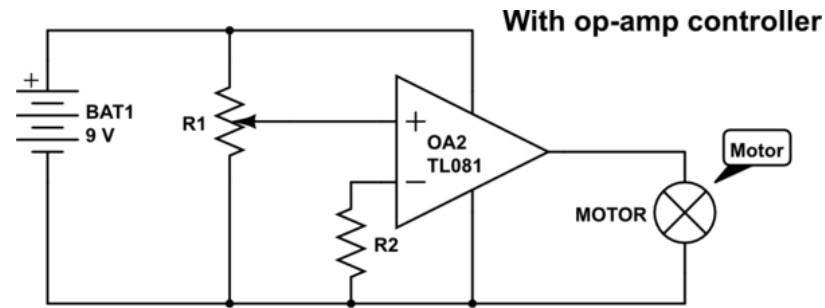

Транзистор - рассеиваемая мощность (тепло)

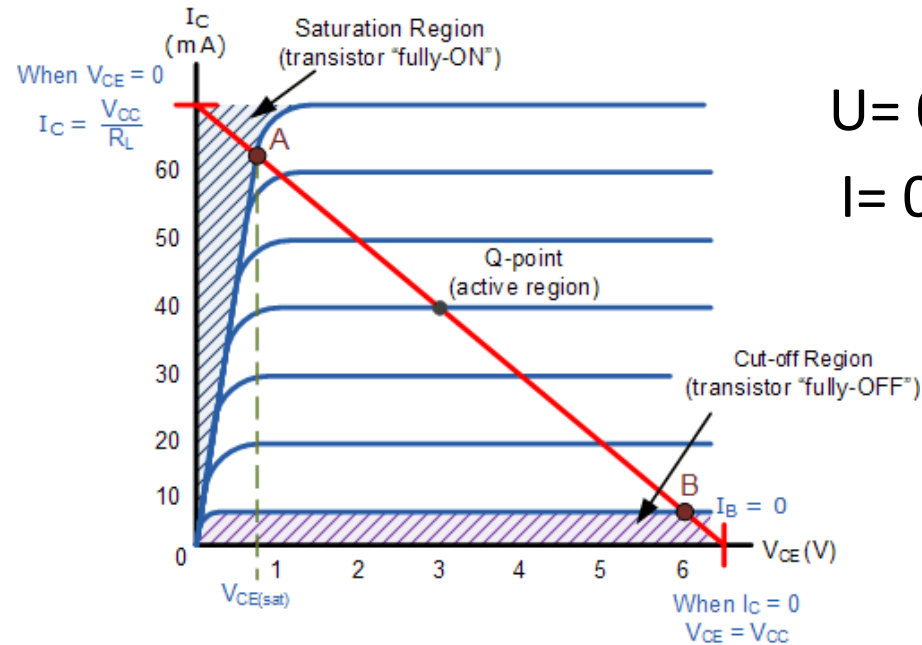
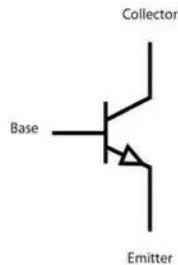
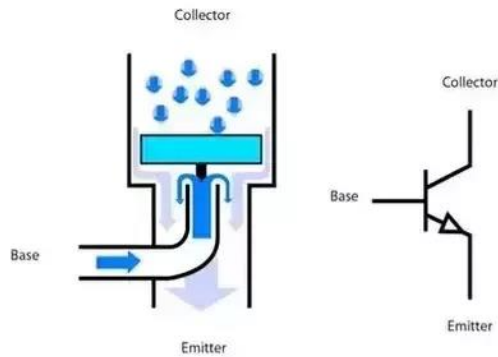
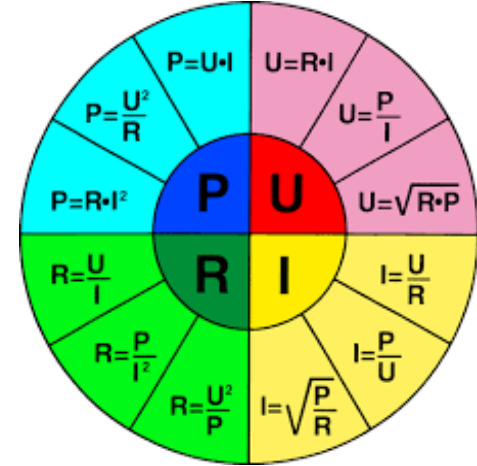
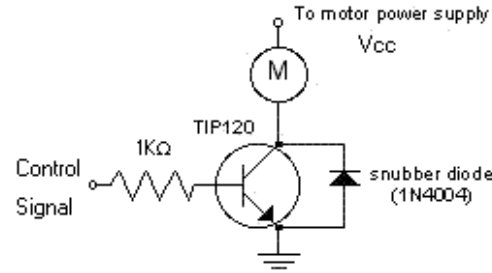
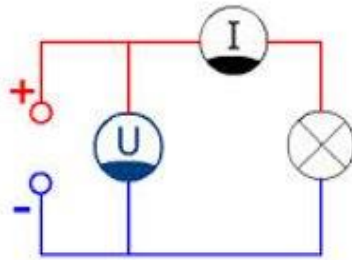
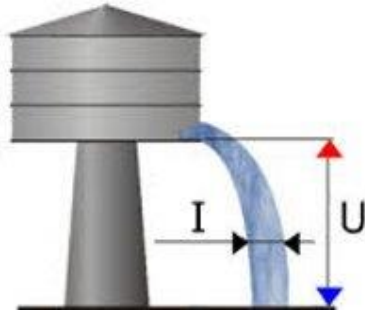

$U = 0 \rightarrow P = 0$

$I = 0 \rightarrow P = 0$



Преобразователь мощности - В КОММУТАЦИИ



$$U = 0 \rightarrow P = 0$$

$$I = 0 \rightarrow P = 0$$

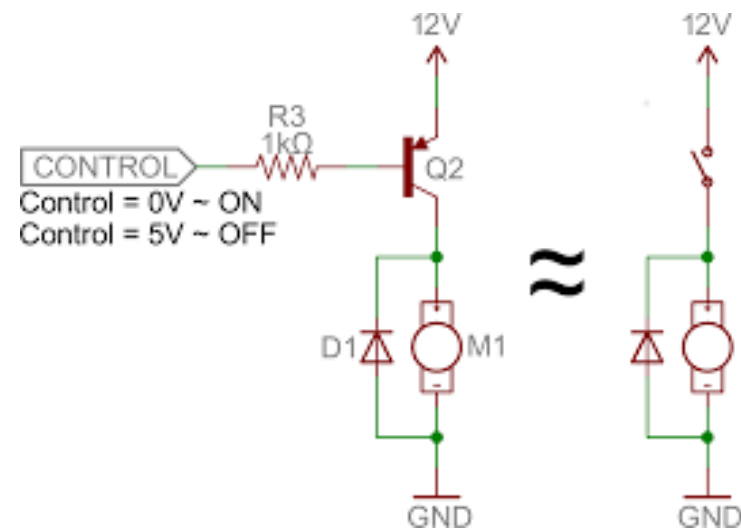
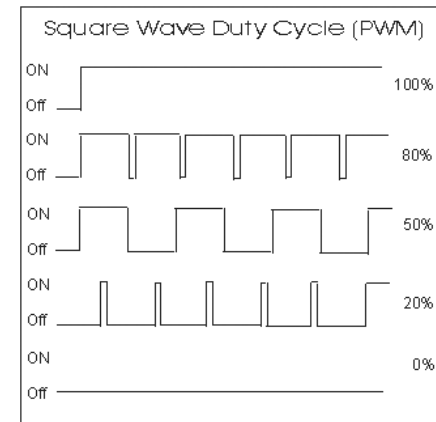
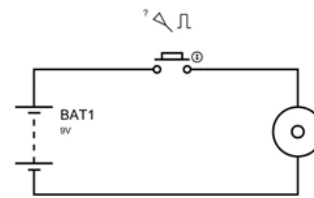

Преобразователь мощности - Мост Н

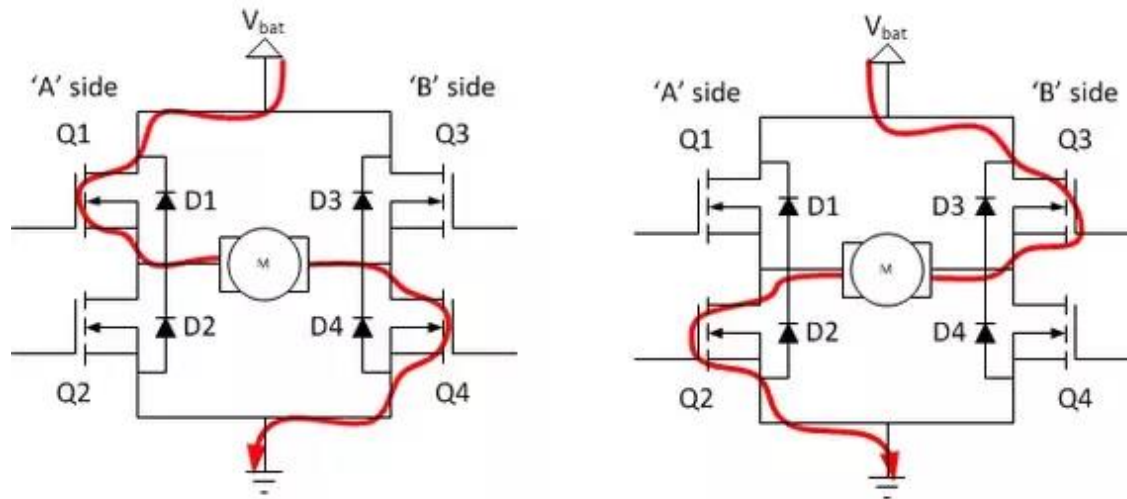
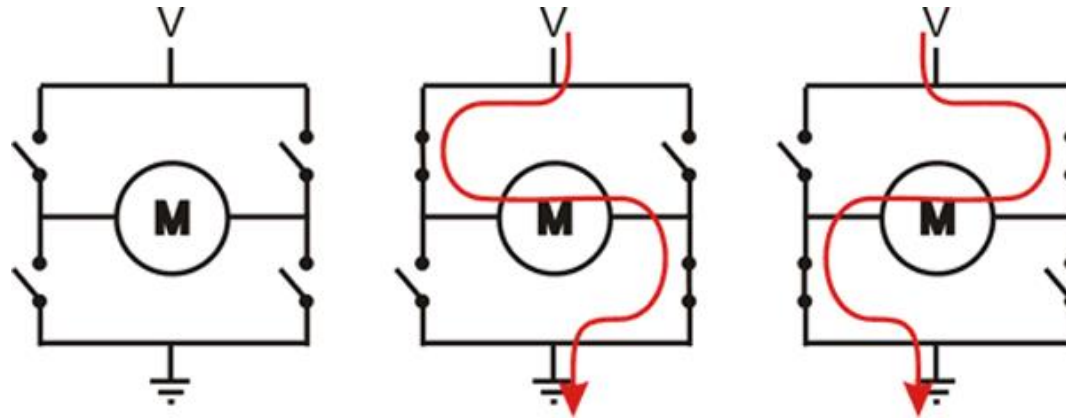

Преобразователь мощности - Мост Н

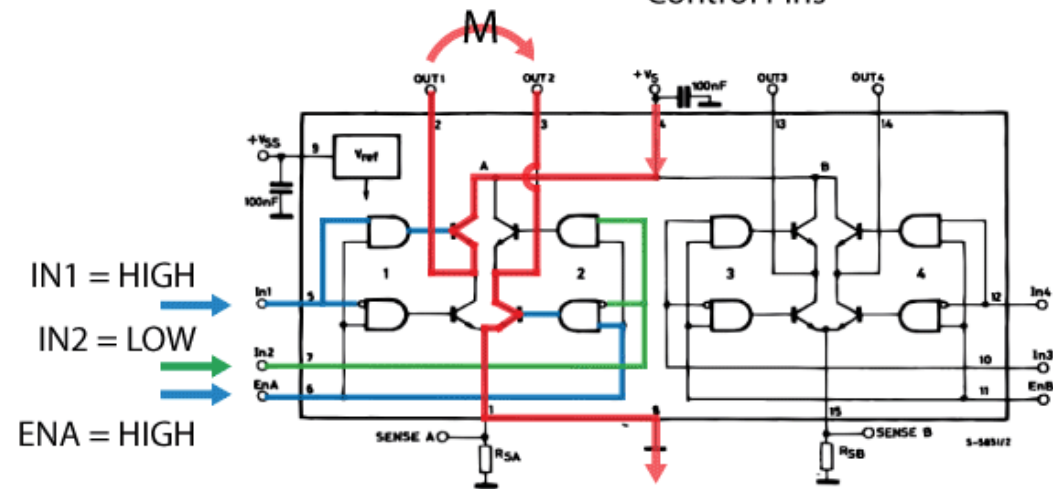
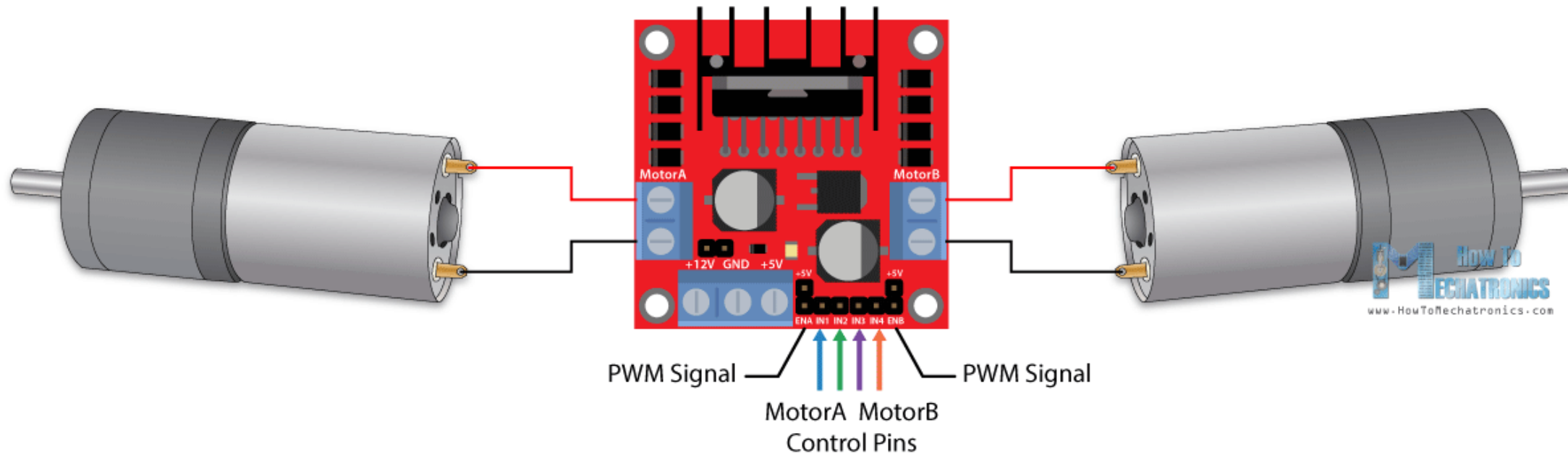

IN1 = HIGH
IN2 = LOW
ENA = HIGH

L298N Block Diagram

* Figure from L298N datasheet

Преобразователь мощности - Мост H BLDC

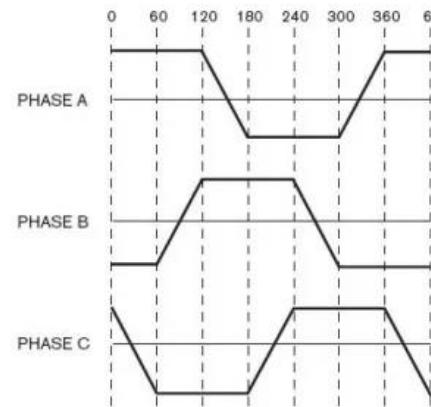
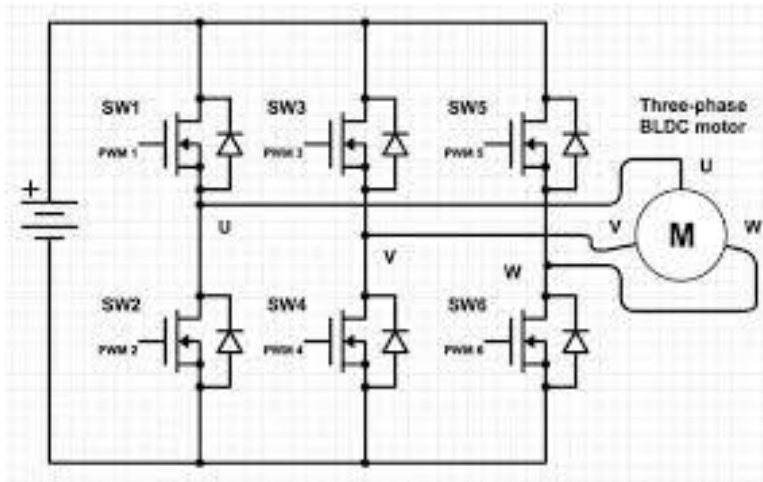

Sinusoidal BLDC Control

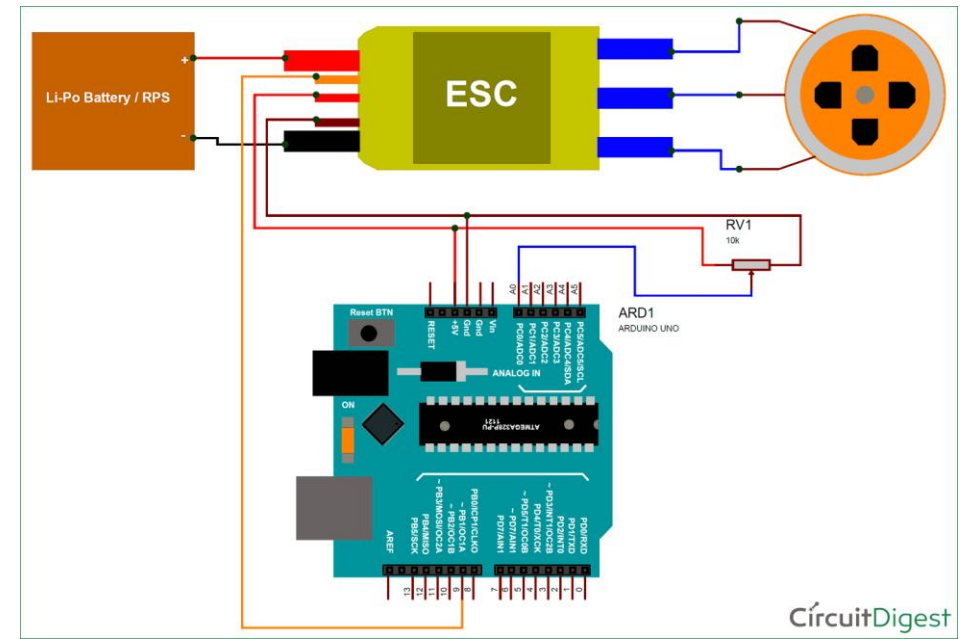
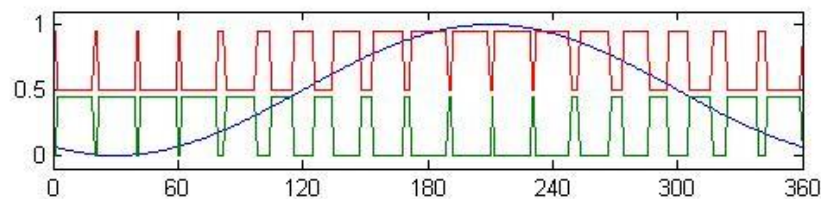
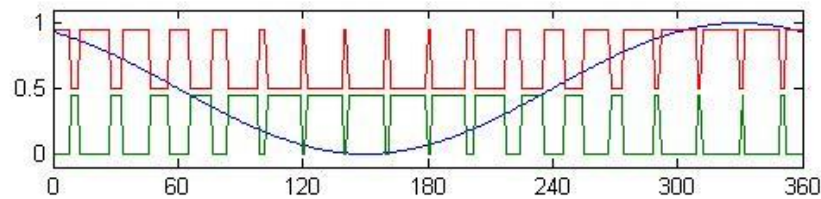
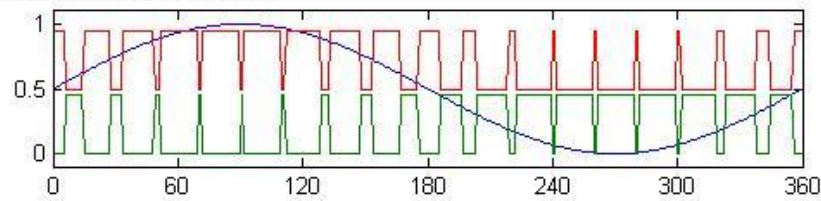
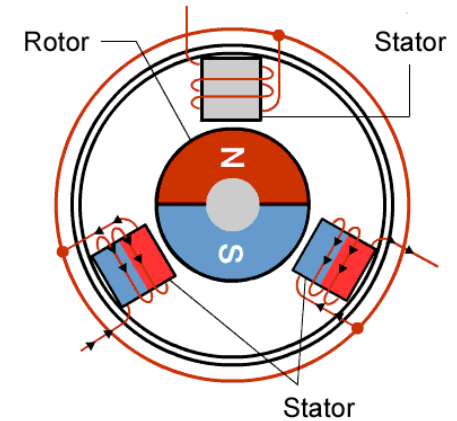
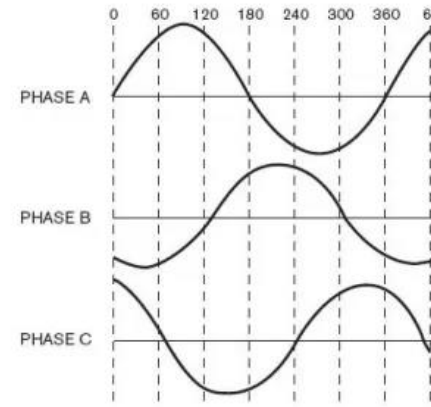

Преобразователь мощности - Мост HStepper

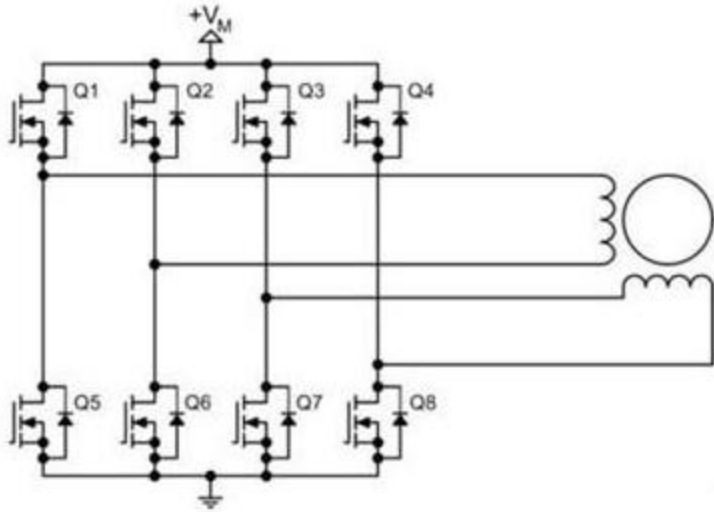
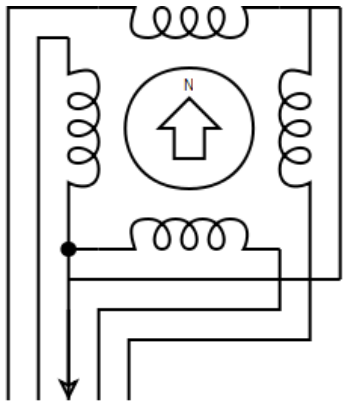
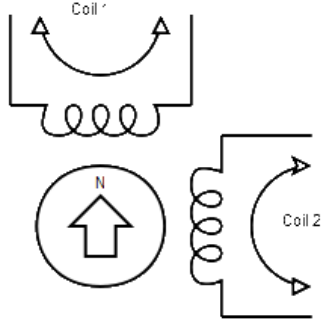

Figure 2



Unipolar Design
(Common connection -
current always one way)



Bipolar Design
(Distinct coils -
current goes either way)

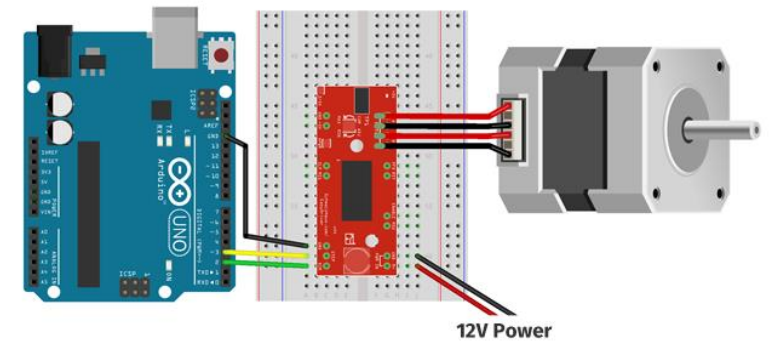
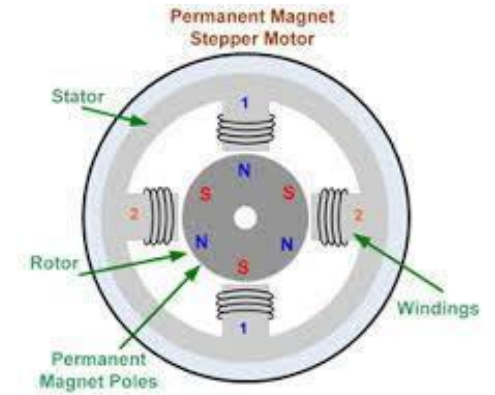
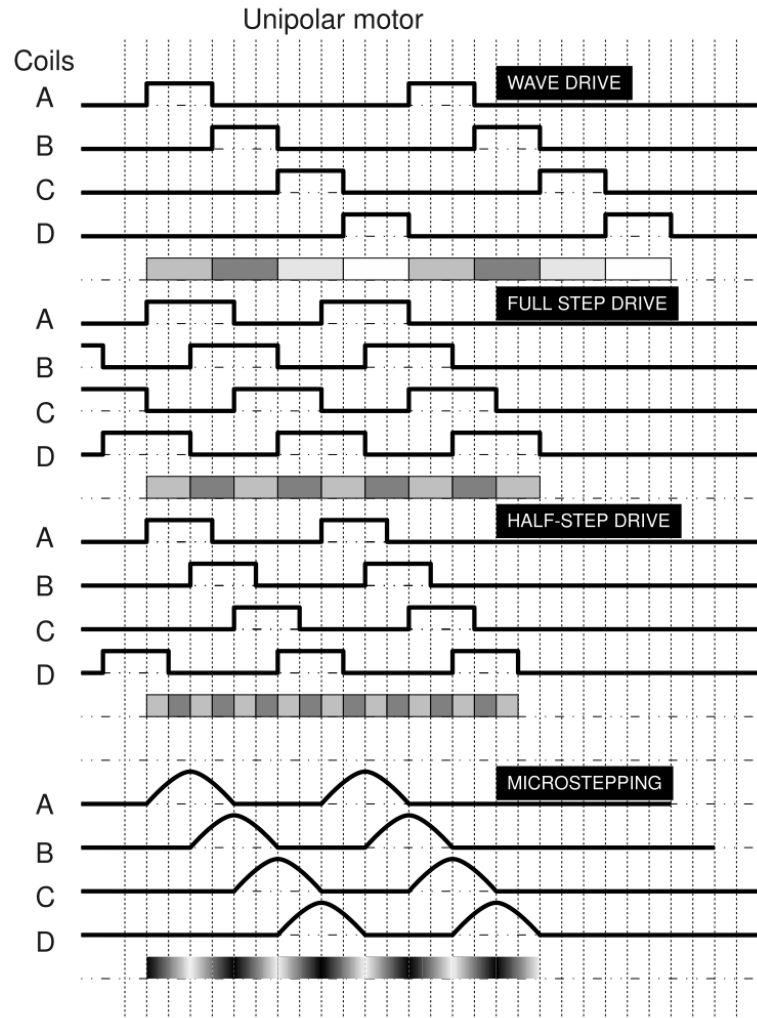

12V Power

Генерація сигналів PWM

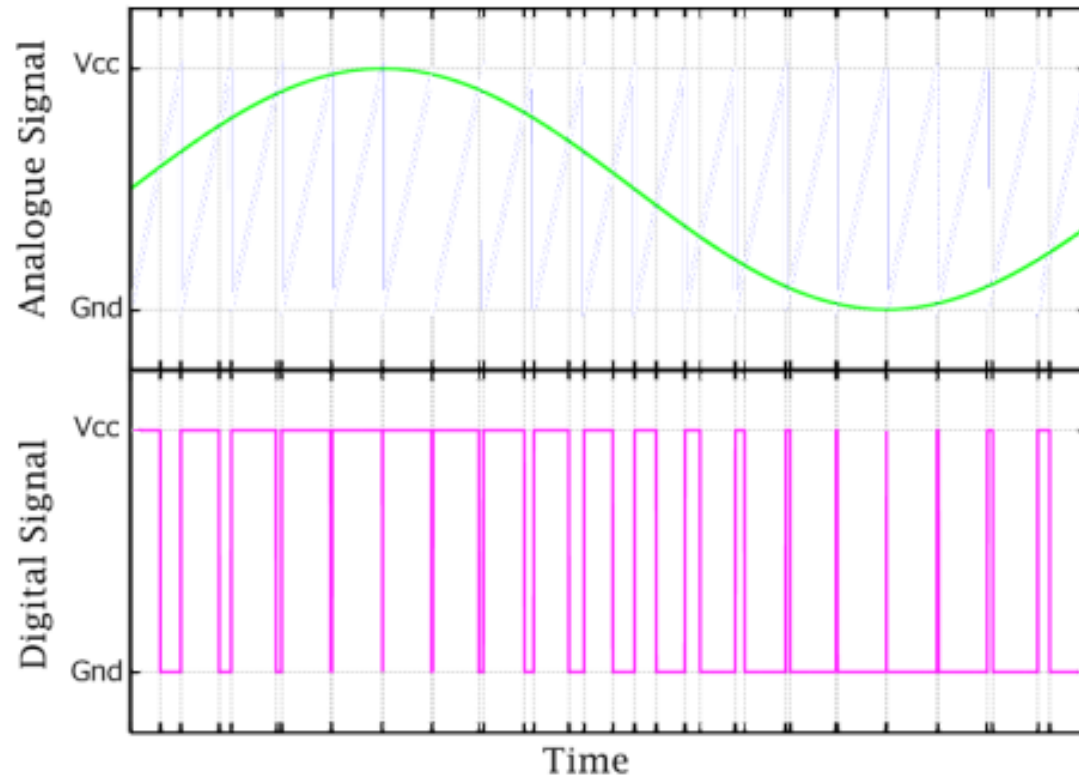

```
AnalogInOutSerial | Arduino 1.8.12 (Windows Store 1.8.33.0) - □ ×
File Edit Sketch Tools Help
AnalogInOutSerial
void setup() {
  // initialize serial communications at 9600 bps:
  Serial.begin(9600);
}

void loop() {
  // read the analog in value:
  sensorValue = analogRead(analogInPin);
  // map it to the range of the analog out:
  outputValue = map(sensorValue, 0, 1023, 0, 255);
  // change the analog out value:
  analogWrite(analogOutPin, outputValue);

  // print the results to the Serial Monitor:
  Serial.print("sensor = ");
  Serial.print(sensorValue);
  Serial.print("\t output = ");
  Serial.println(outputValue);

  // wait 2 milliseconds before the next loop for the anal
  // converter to settle after the last reading:
  delay(2);
}
1 Arduino Uno on COM5
```

Датчик-привод Signal Conditioning flow

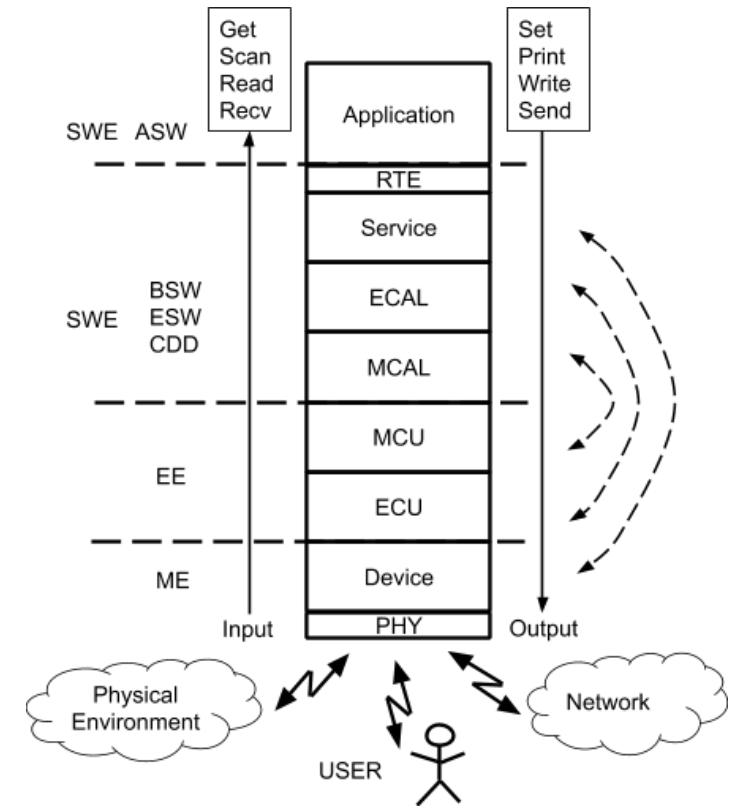
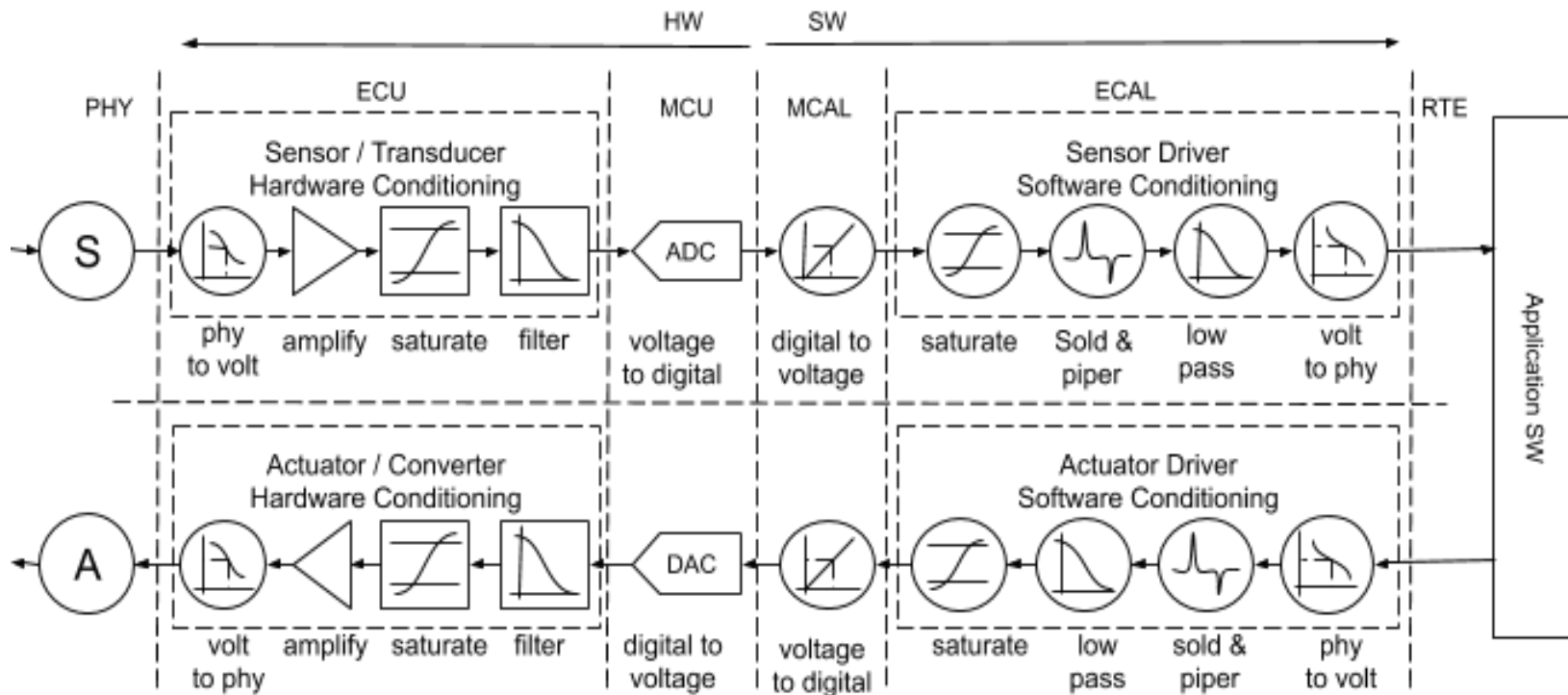
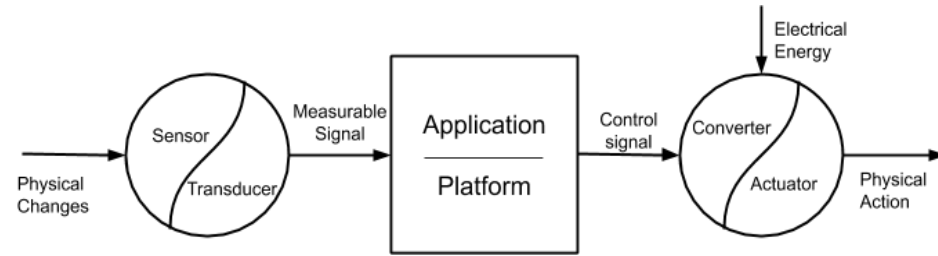
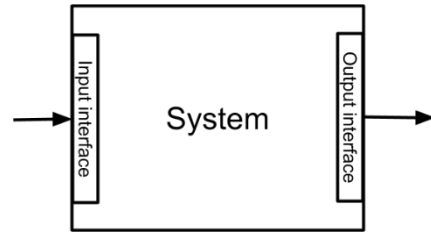

Генерация сигналов

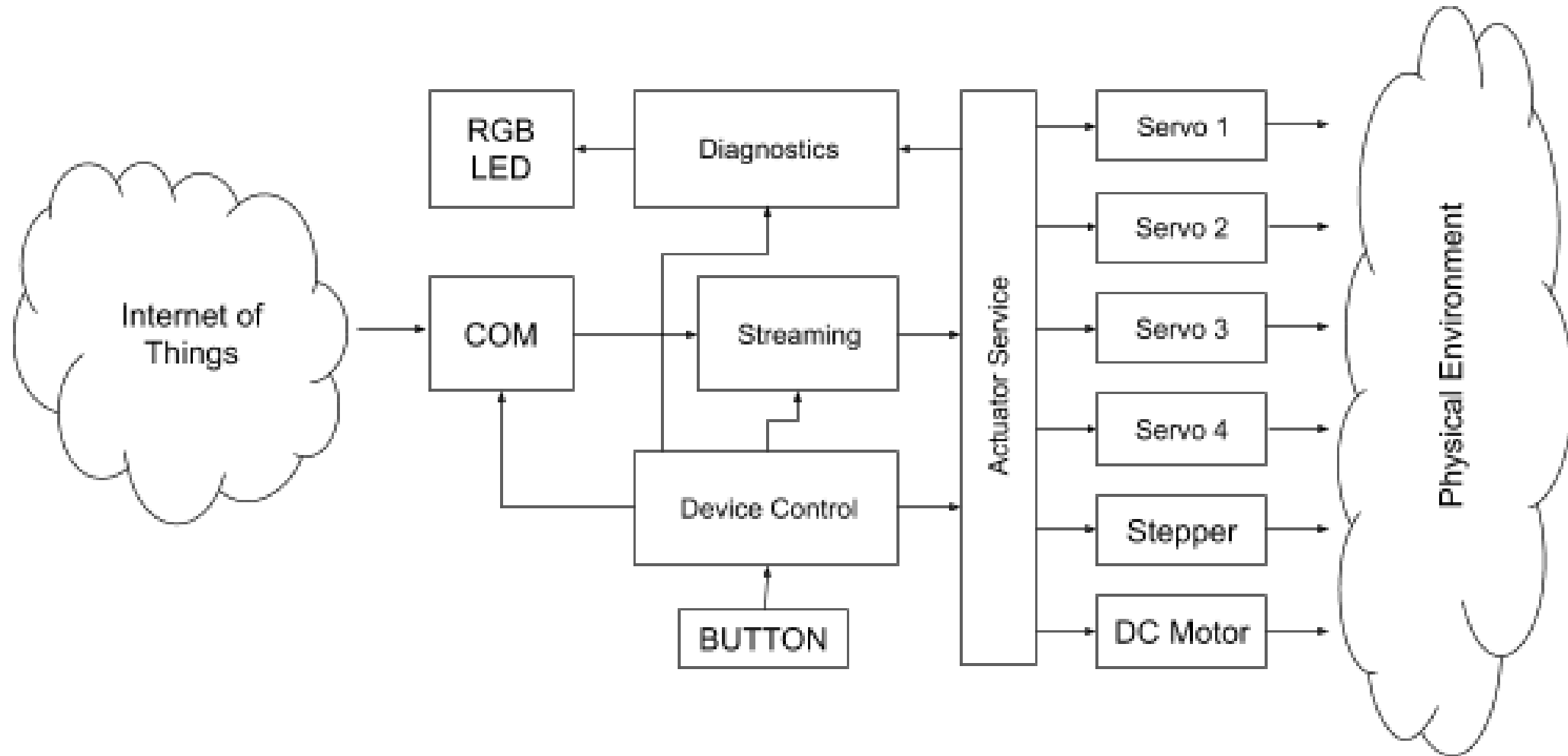

Многоуровневая архитектура

